

BERARMA
oleodinamica

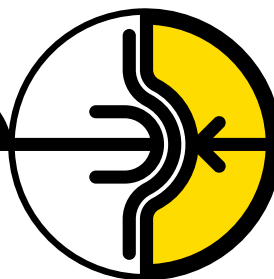

Variable displacement vane pump with mechanical pressure compensator

PLP



Series Name	Displacement [cm ³ /r]	Flow rate at 1450rpm [l/min]	Max Pressure [bar]
01 PLP 05-16	16	23	120
01 PLP 1-20	20	29	100
01 PLP 1-25	25	36	100
01 PLP 1-32	32	47	100
01 PLP 2-40	40	58	100
01 PLP 2-50	50	73	100
01 PLP 2-63	63	92	100
01 PLP 3-80	80	116	90
01 PLP 3-100	100	145	90
01 PLP 3-120	120	174	90

General description

PLP pumps are low pressure variable displacement vane pumps equipped with a mechanical pressure regulating device that allow you to instantly adjust the flow rate accordingly to circuit requirements. Variable displacement vane pumps are volumetric type so they deliver a maximum flow rate equivalent to its displacement for their speed of rotation. Operating pressure is due to pressure loads encountered by the fluid within the system. When the outlet pressure (on the system) equals the pump setting pressure, the flow rate is adjusted to the values required by the system. When this value is achieved, pump reduces its flow rate to zero, keeping the pressure almost constant. In zero flow conditions, pump delivers oil only to compensate any possible drain and piloting.

The series of PLP pumps, like all other Berarma variable displacement vane pumps, ensure:

- Silent running
- High efficiency
- Long working life
- Economy and simplification of hydraulic system
- Modular design
- Energy saving

The innovation related to the series of vane pumps has led to an improvement of displacement control dynamics and improved axial balancing thanks to the refinement of the hydrostatic compensation of the distribution plates.

The series of PLP pumps is supplied with:

- ISO standard mounting flanges and shafts
- Gas BSP and/or SAE 3000 standard port connections
- Max. flow regulator unit to mechanically reduce pump max. displacement
- Mechanical pressure regulating device
- Thru drive shaft (only with the option "A") to arrange combined pumps between Berarma pumps or the main other types of pump available on the fluid power market

What makes the Berarma PLP series pumps very interesting for the market?

- Innovative shapes and design
- Compact overall dimensions
- Wear reduction of the internal pump cartridge parts

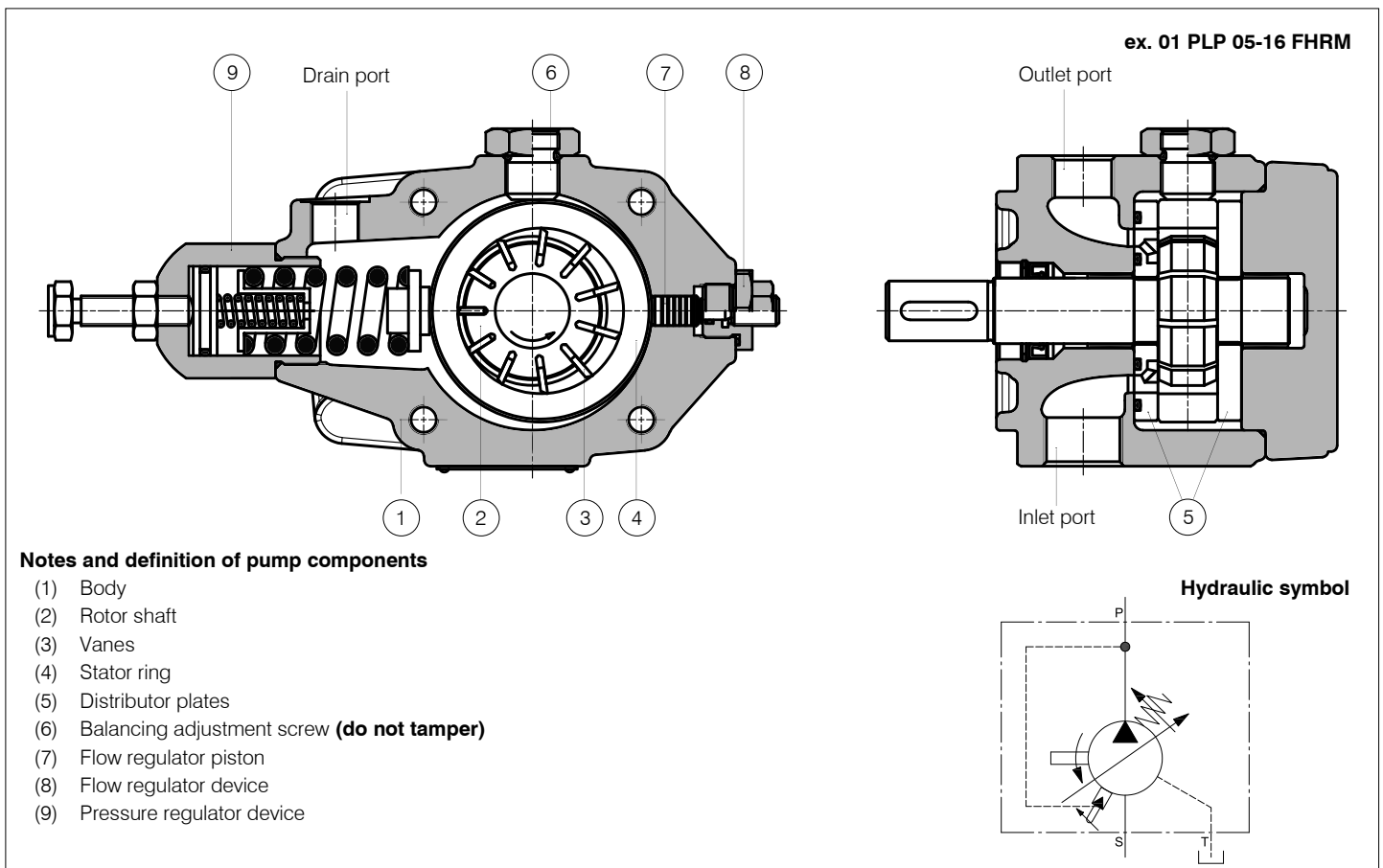

Notes and definition of pump components

- (1) Body
- (2) Rotor shaft
- (3) Vanes
- (4) Stator ring
- (5) Distributor plates
- (6) Balancing adjustment screw **(do not tamper)**
- (7) Flow regulator piston
- (8) Flow regulator device
- (9) Pressure regulator device

Technical data

Size	05	1	2	3
Geometric displacement according to ISO 3662 (cm ³ /r)	16	20 ÷ 25 ÷ 32	40 ÷ 50 ÷ 63	80 ÷ 100 ÷ 120
Actual displacement (cm ³ /r) Due to manufacturing tolerances, the value can vary by approx. ±3%	17	21 ÷ 26 ÷ 33	41 ÷ 50 ÷ 63	81 ÷ 100 ÷ 120
Maximum working pressure (bar) Pressure peak exceeding 30% of the maximum operating pressure must be eliminated by adopting the appropriate measures	120	100		90
Pressure setting range (bar)	H: 20 ÷ 120	L: 15 ÷ 50 H: 30 ÷ 100		L: 30 ÷ 50 H: 50 ÷ 90
Permitted maximum drain port pressure (bar)	1			
Inlet pressure (bar)	0.8 ÷ 1.5 absolute			
Speed range (rpm)	300 ÷ 1800 with Pmax 100bar 500 ÷ 1800 with Pmax 120bar		500 ÷ 1800	
Rotation direction	R: right (clockwise) viewed from shaft end			
Load on drive shaft	NO RADIAL OR AXIAL LOADS ALLOWED			
Hydraulic fluid for other fluids please contact Berarma technical sales service	HM according to ISO 6743-4 HLP according to DIN 51524-2			
	HEES according to ISO 15380 FPM-Viton seals			
	HFD according to ISO 12922 FPM-Viton seals			
	HFC according to ISO 12922 water <40% ÷ NBR seals ÷ Vmax 1000rpm ÷ Temp. <40°C			
Viscosity range (cSt, mm ² /s)	22 ÷ 68 at operating temperature			
Starting viscosity under full flow conditions (cSt, mm ² /s)	400 max.			
Viscosity index according to ISO 2909	100 min.			
Inlet fluid temperature range (°C)	+15 / +60 ÷ pay attention to viscosity range			
Maximum acceptable fluid contamination level	20/18/15 according to ISO 4406 CLASS 9 according to NAS 1638			
Recommended fluid contamination level for a longer pump working life	18/16/13 according to ISO 4406 CLASS 7 according to NAS 1638			
Moment of inertia (kgm ²)	0.00012	0.0005	0.00909	0.015
Weight single pump (kg)	7.4	18.4	35.5	53.5
For further information and/or different operating conditions please contact Berarma technical sales service				

Installation and start-up

For the installation and start-up of Berarma pumps please refer to related **Document USE AND MAINTENANCE MANUAL** available on our website.



Ordering code

Series Name	Size Displacement	Flange	Pressure setting	Rotation	Seals	Options
01 PLP	05 – 16	F	H	R	M	A

Code	Size	Displacement cm ³ /r
05 – 16	05	16
1 – 20	1	20
1 – 25	1	25
1 – 32	1	32
2 – 40	2	40
2 – 50	2	50
2 – 63	2	63
3 – 80	3	80
3 – 100	3	100
3 – 120	3	120

Code	Flange	Ports
F	ISO 3019-2 4 holes	Gas BSP SAE 3000
FGR2 <small>only for size 05</small>	Rectangular gear pump 2	Gas BSP

Code	Pressure setting (bar)
L	15 ÷ 50 for size 1 and 2 30 ÷ 50 for size 3
H	20 ÷ 120 for size 05 30 ÷ 100 for size 1 and 2 50 ÷ 90 for size 3

Code	Rotation direction
R	Right (cw) view from shaft end

Code	Seals
M	NBR
E	FPM – Viton

Code	Option
/	Omit for no option
A	Thru drive shaft for combined pumps (only for flange F)

Ordering code examples:

- 01 PLP 05-16 FGR2 H R M
- 01 PLP 05-16 F H R M A
- 01 PLP 1-32 F L R M
- 01 PLP 2-40 F H R M A
- 01 PLP 3-120 F H R M A

Characteristic curves

01 PLP 05-16

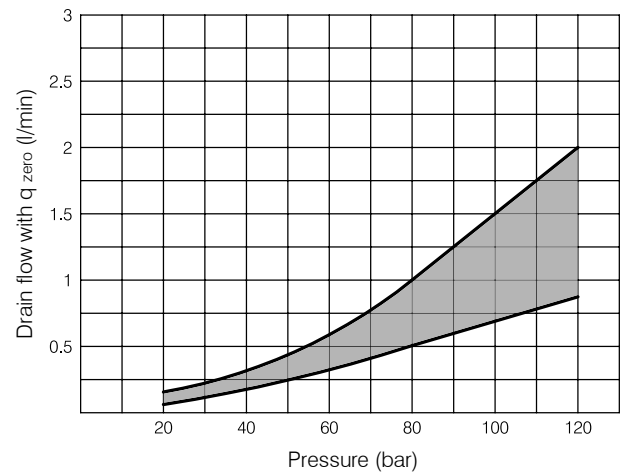
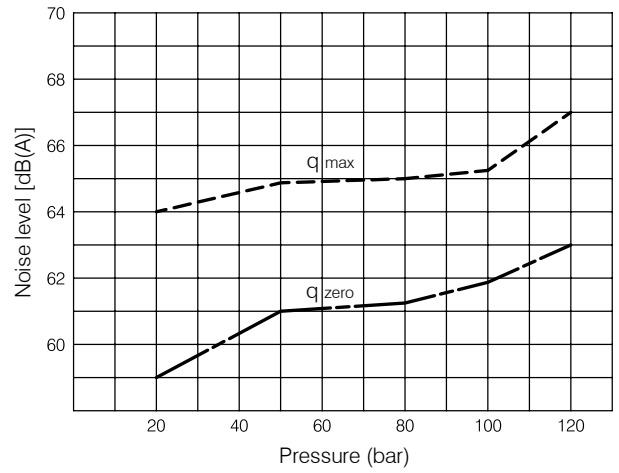
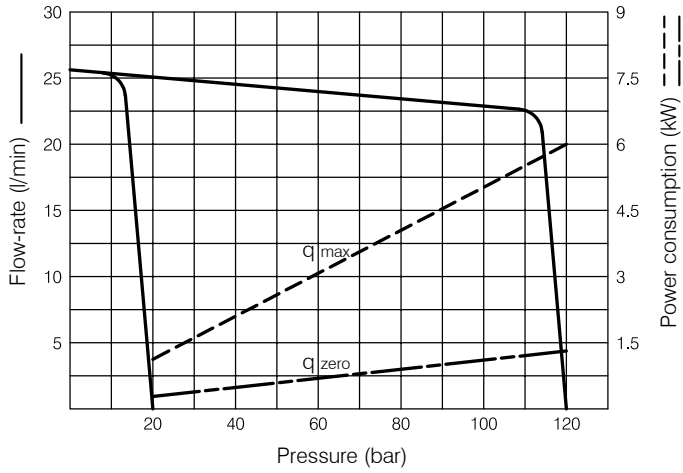

Indicative values measured on Berarma test stand, referring to 1500 rpm with HM hydraulic oil according to ISO 6743-4, ISO VG 46 according to ISO 3448, temperature 40 °C. Sound level meter placed 1 meter from the pump with flexible coupling.

Characteristic curves

01 PLP 1-20

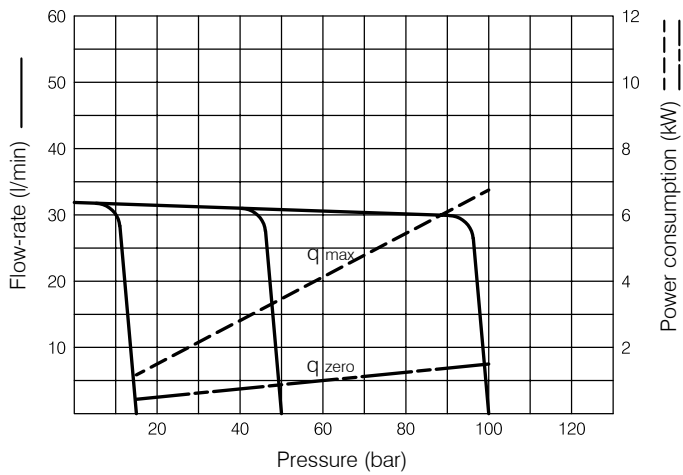

01 PLP 1-(20-25-32)

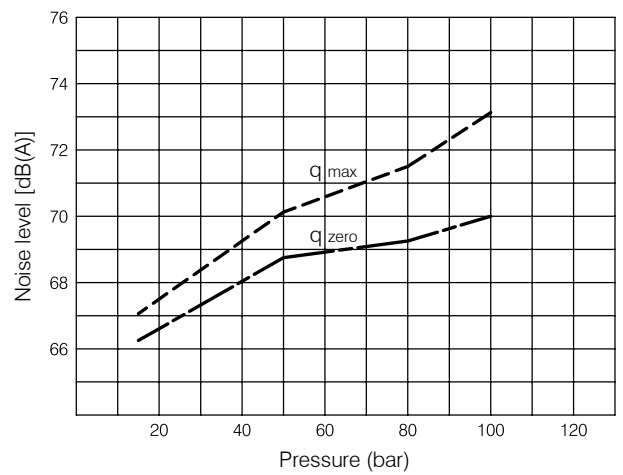

01 PLP 1-25

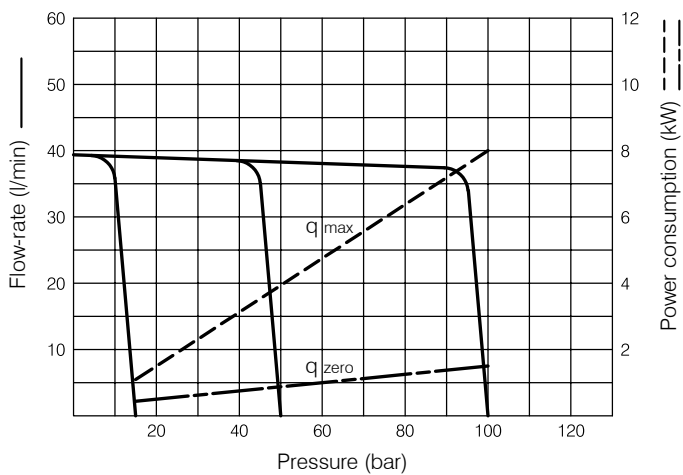

01 PLP 1-(20-25-32)

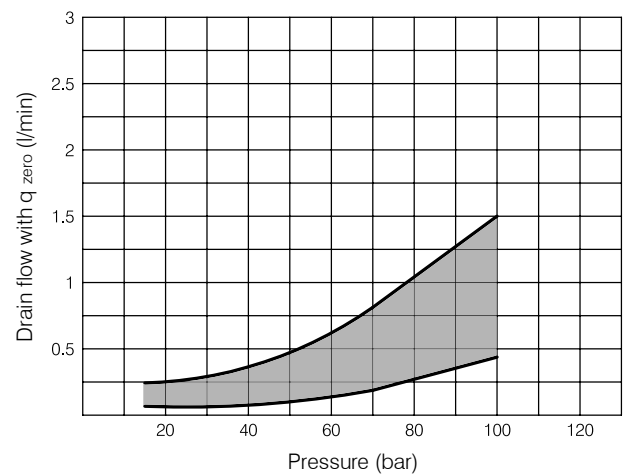

01 PLP 1-32

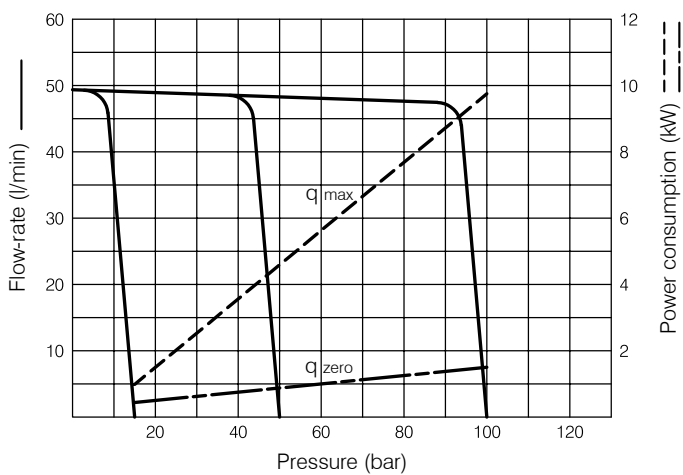

Indicative values measured on Berarma test stand, referring to 1500 rpm with HM hydraulic oil according to ISO 6743-4, ISO VG 46 according to ISO 3448, temperature 40 °C. Sound level meter placed 1 meter from the pump with flexible coupling.

Characteristic curves

01 PLP 2-40

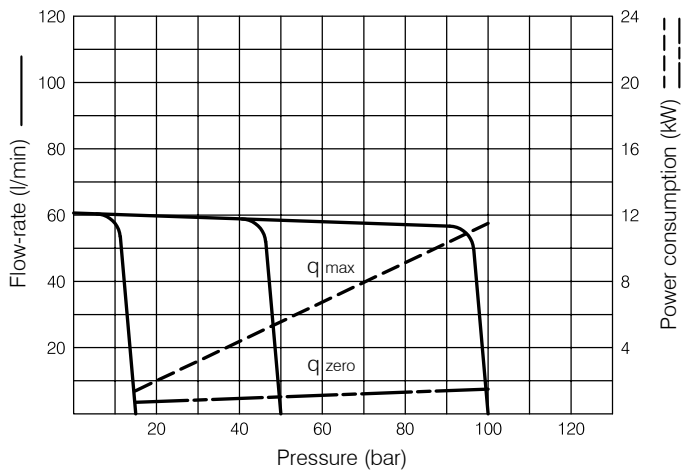

01 PLP 2-(40-50-63)

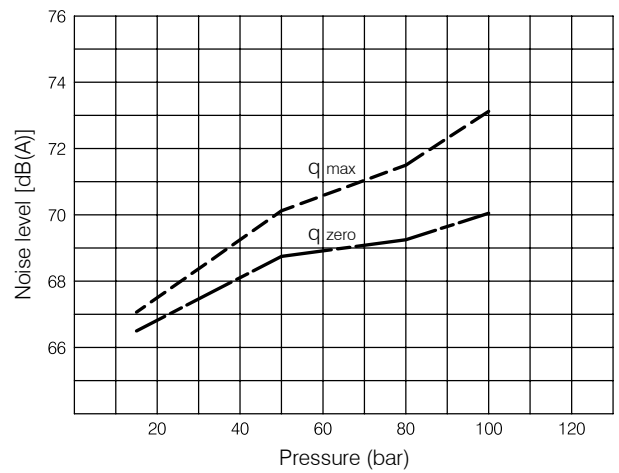

01 PLP 2-50

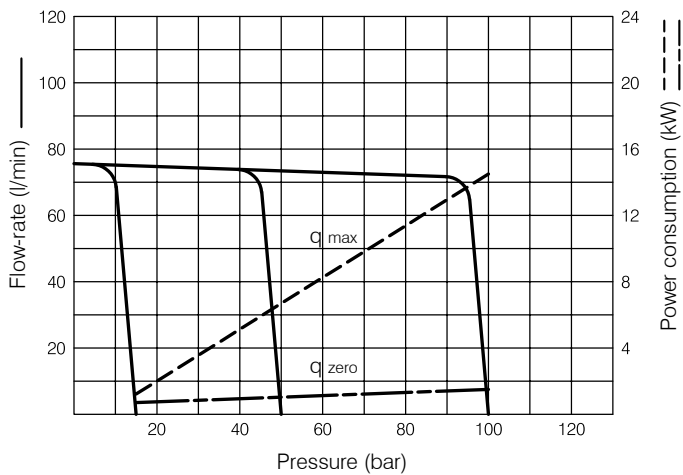

01 PLP 2-(40-50-63)

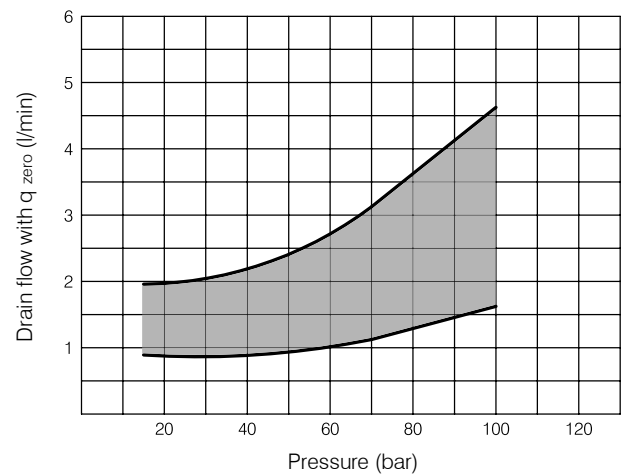

01 PLP 2-63

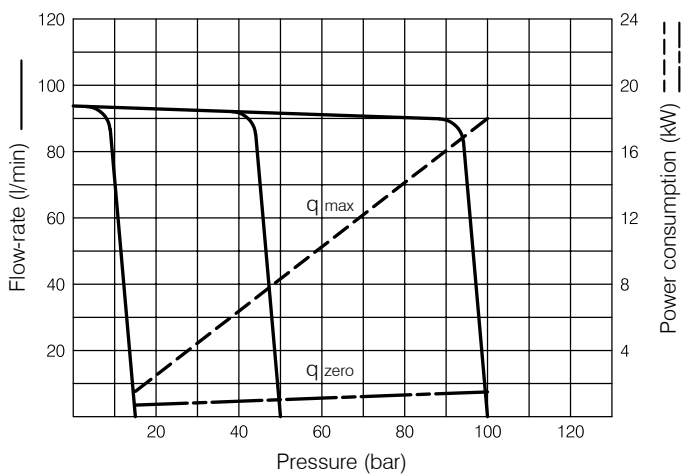

Indicative values measured on Berarma test stand, referring to 1500 rpm with HM hydraulic oil according to ISO 6743-4, ISO VG 46 according to ISO 3448, temperature 40 °C. Sound level meter placed 1 meter from the pump with flexible coupling.

Characteristic curves

01 PLP 3-80

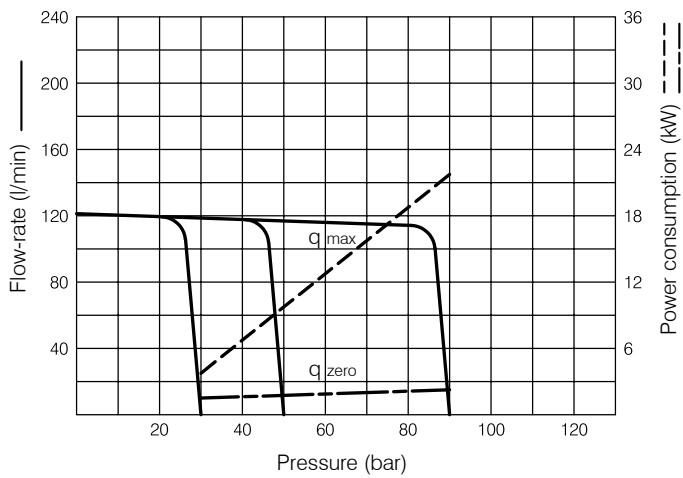

01 PLP 3-(80-100-120)

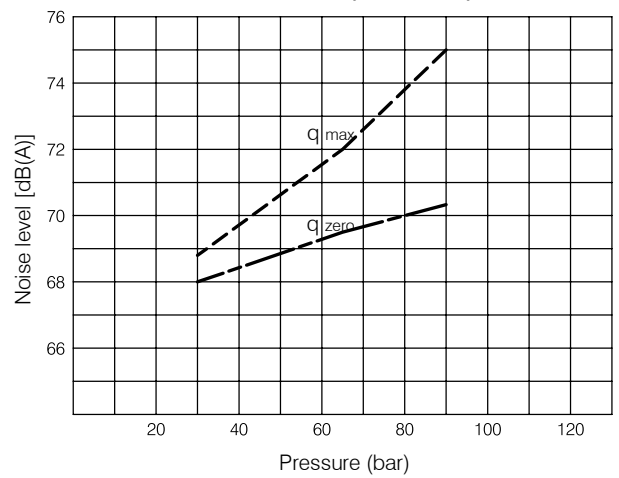

01 PLP 3-100

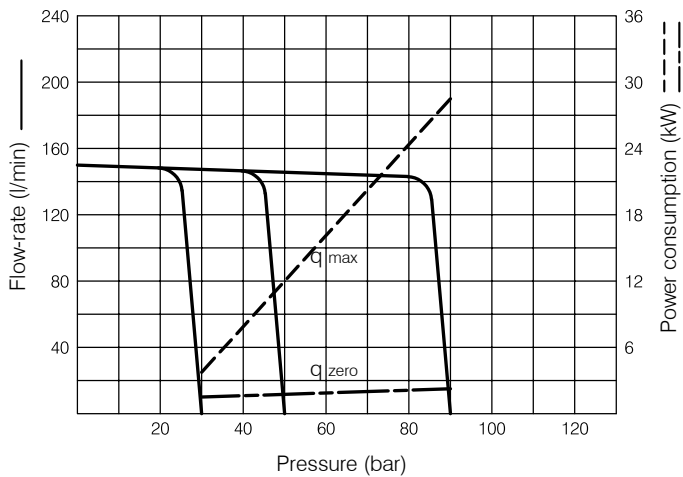

01 PLP 3-(80-100-120)

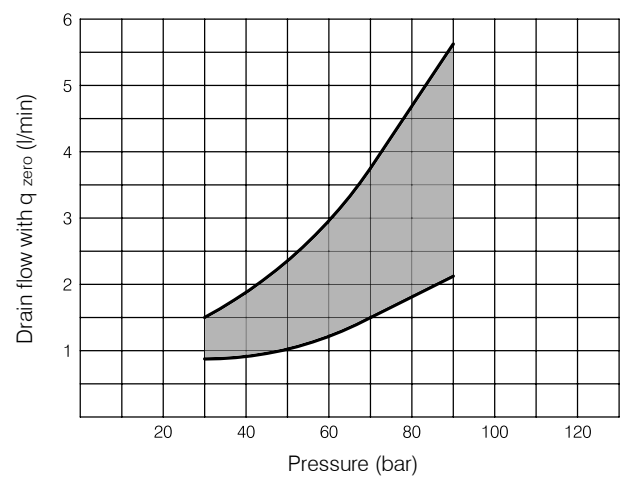

01 PLP 3-120

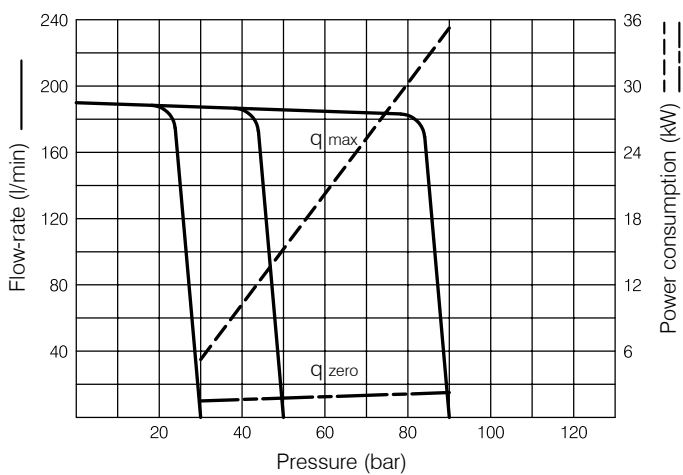

Indicative values measured on Berarma test stand, referring to 1500 rpm with HM hydraulic oil according to ISO 6743-4, ISO VG 46 according to ISO 3448, temperature 40 °C. Sound level meter placed 1 meter from the pump with flexible coupling.

Overall dimensions

01 PLP 05-16 – Flange “F”

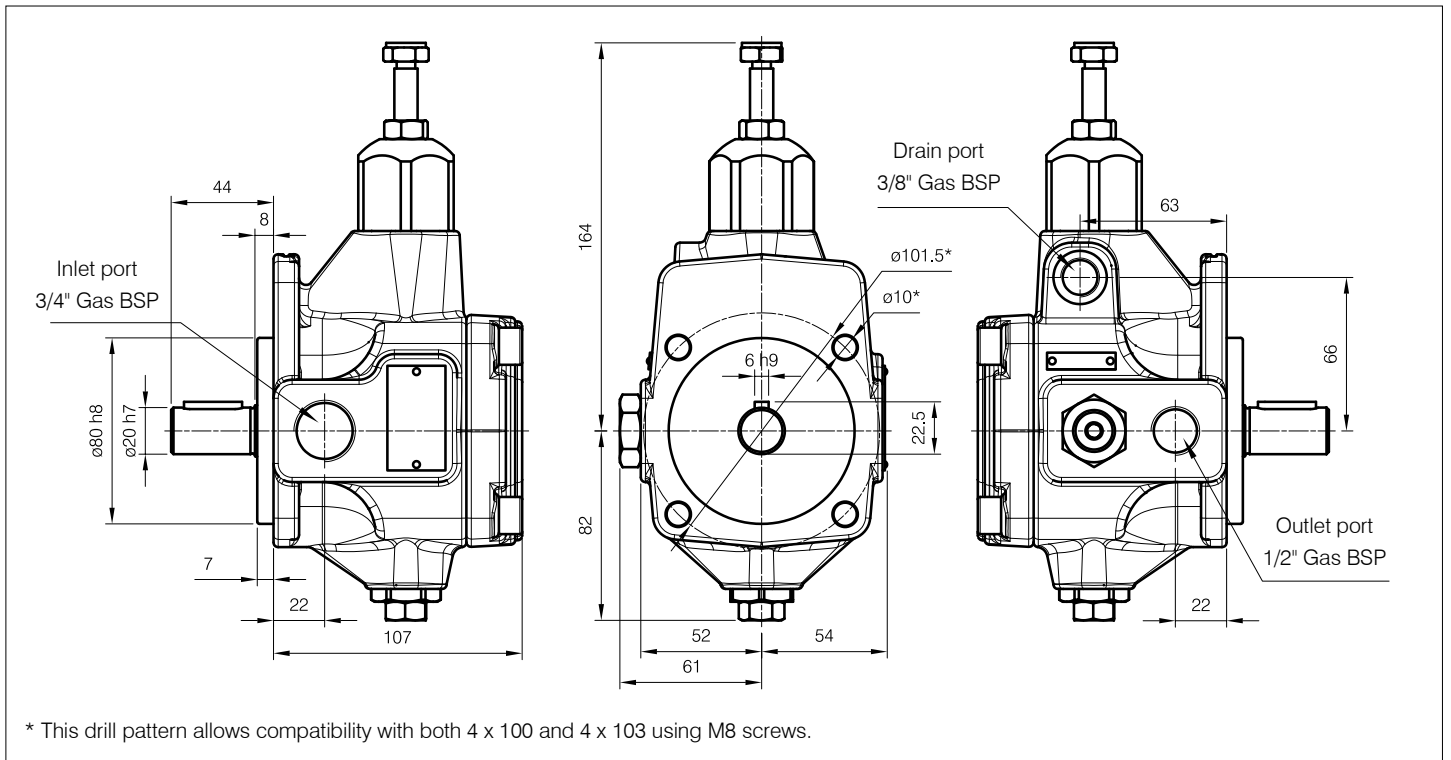

01 PLP 05-16 – Flange “F” + Option “A”

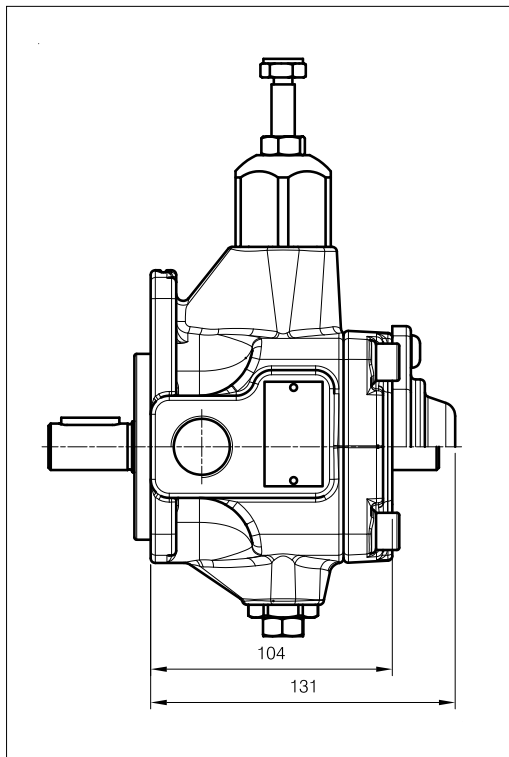

01 PLP 05-16 – Flange “FGR2”

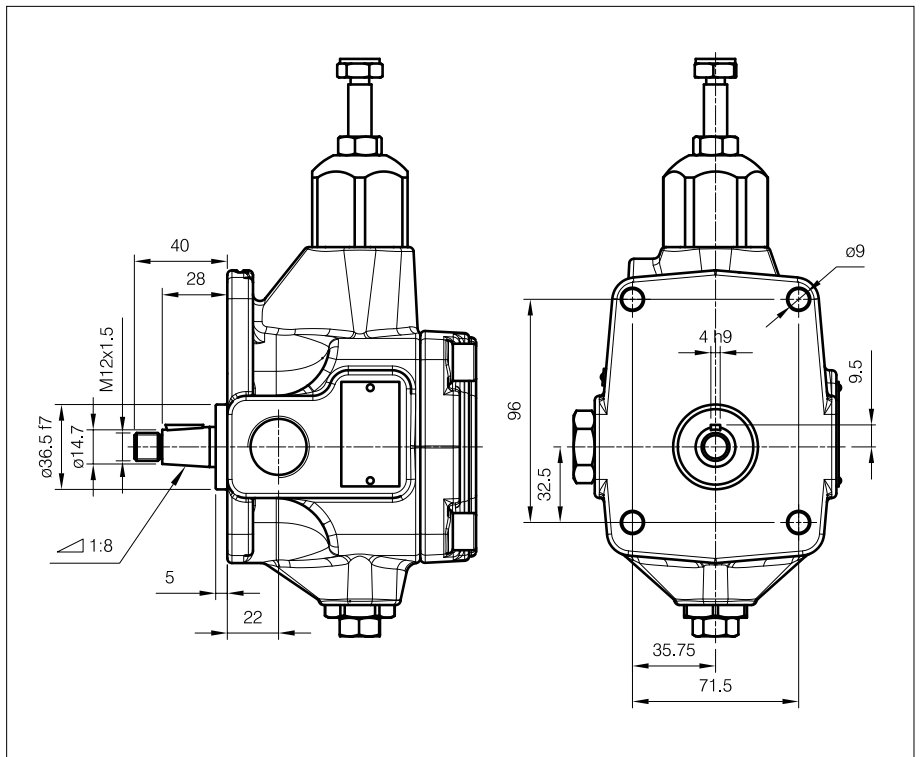

For information, please refer to related **Catalog COUPLINGS and ACCESSORIES**

Overall dimensions

01 PLP 1-(20-25-32)

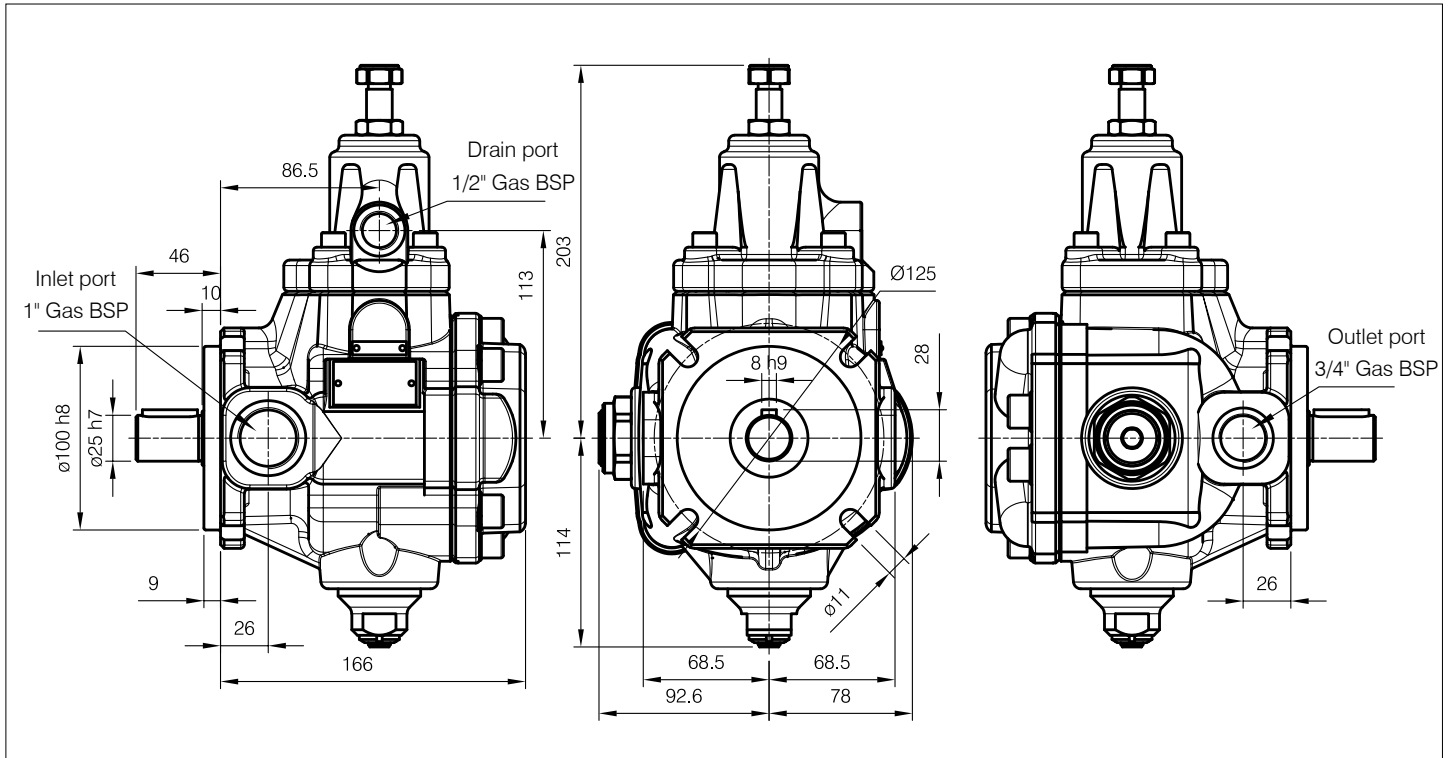

01 PLP 1-(20-25-32) + Option "A"

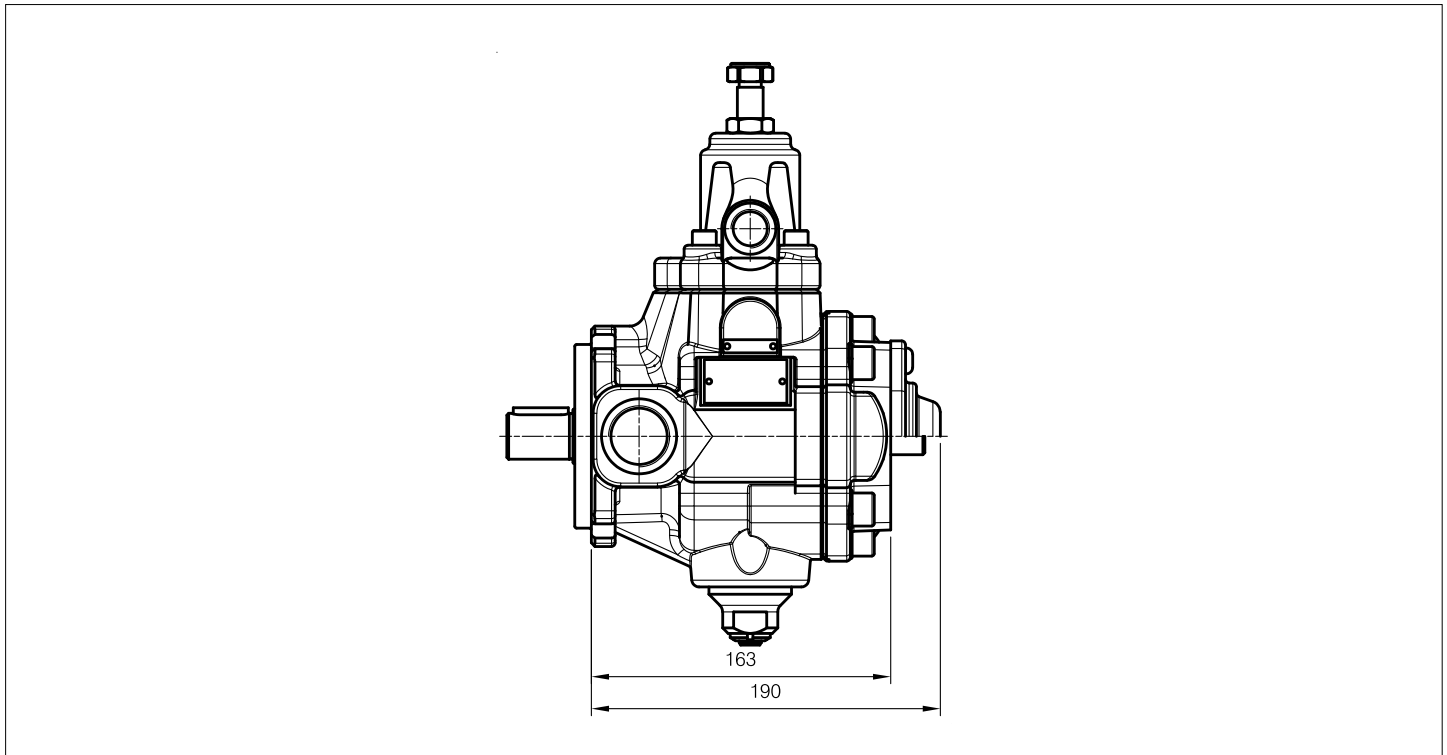

For information, please refer to related **Catalog COUPLINGS and ACCESSORIES**

Overall dimensions

01 PLP 2-(40-50-63)

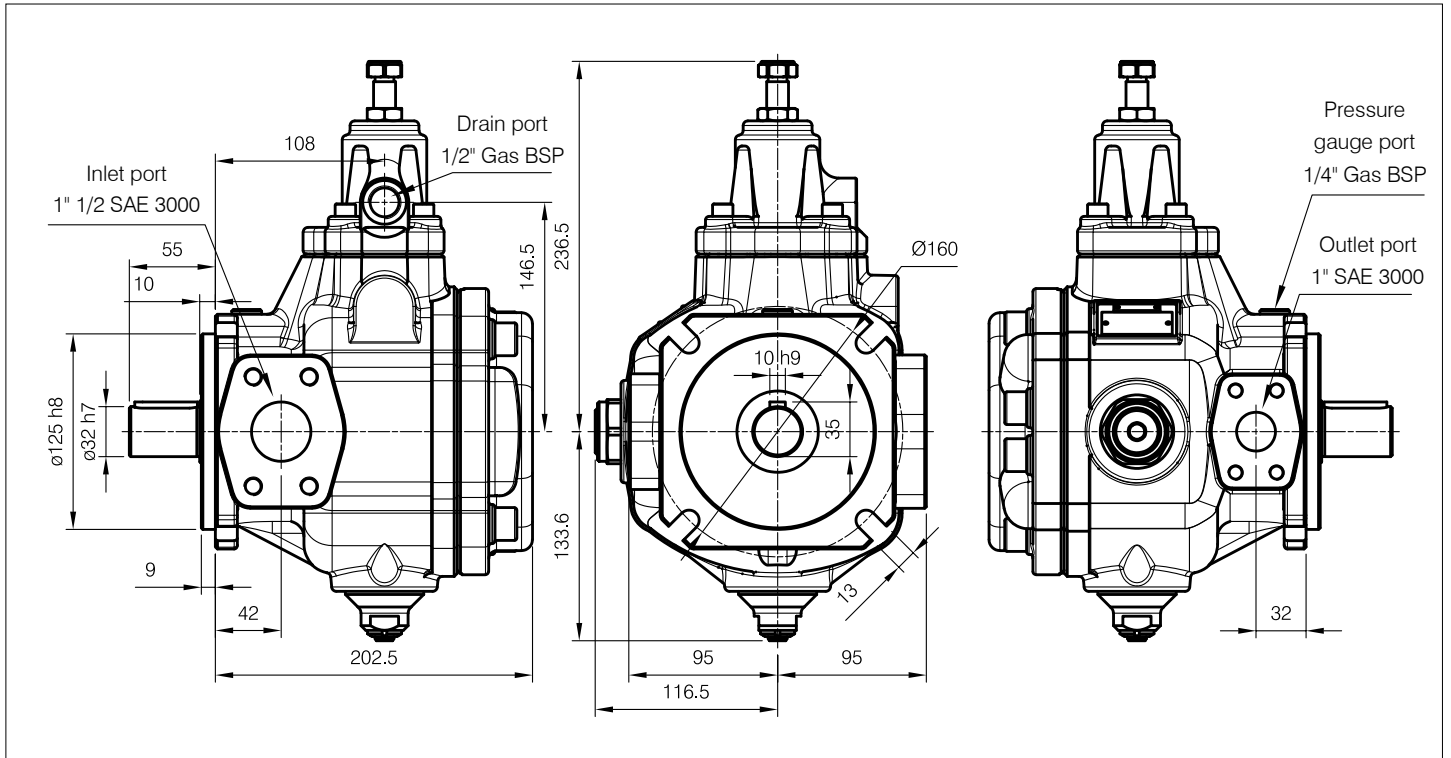

01 PLP 2-(40-50-63) + Option "A"

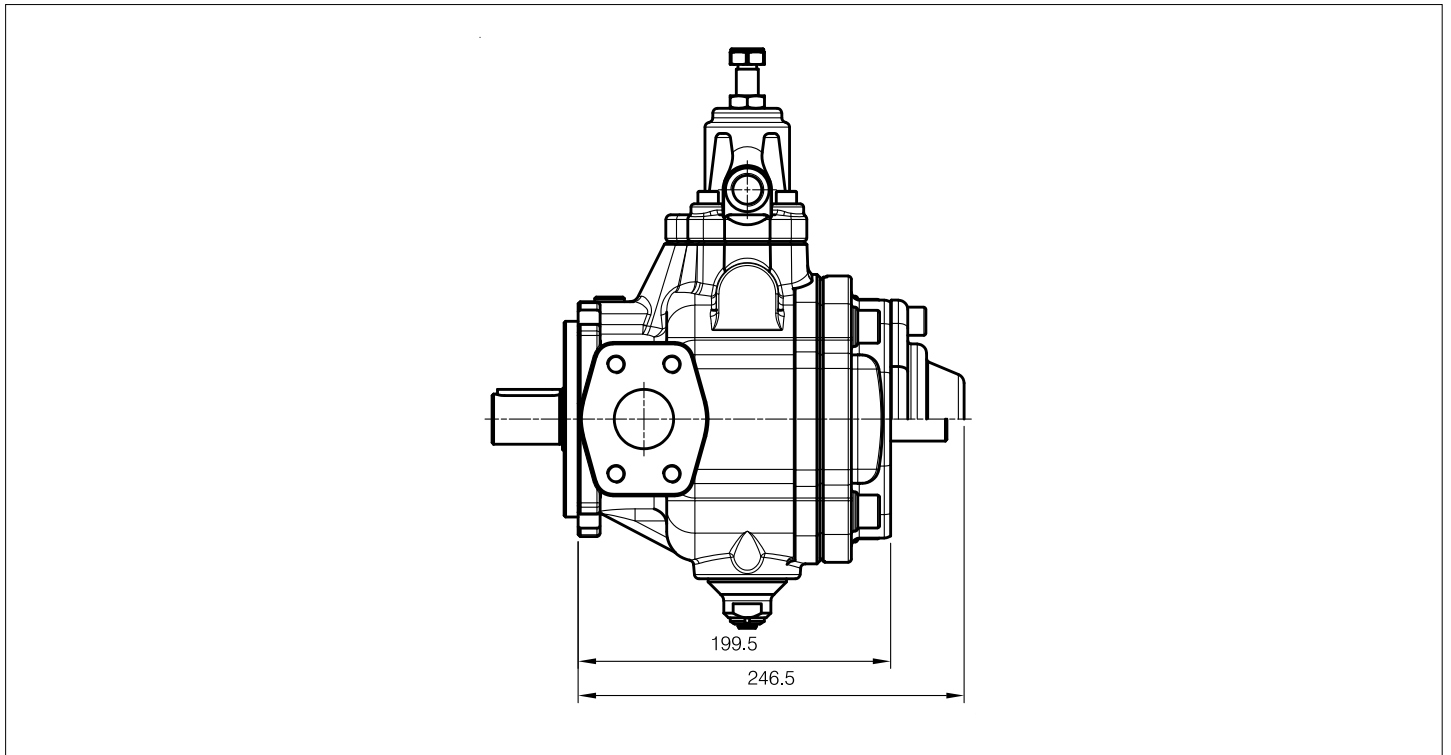

For information, please refer to related **Catalog COUPLINGS and ACCESSORIES**

Overall dimensions

01 PLP 3-(80-100-120)

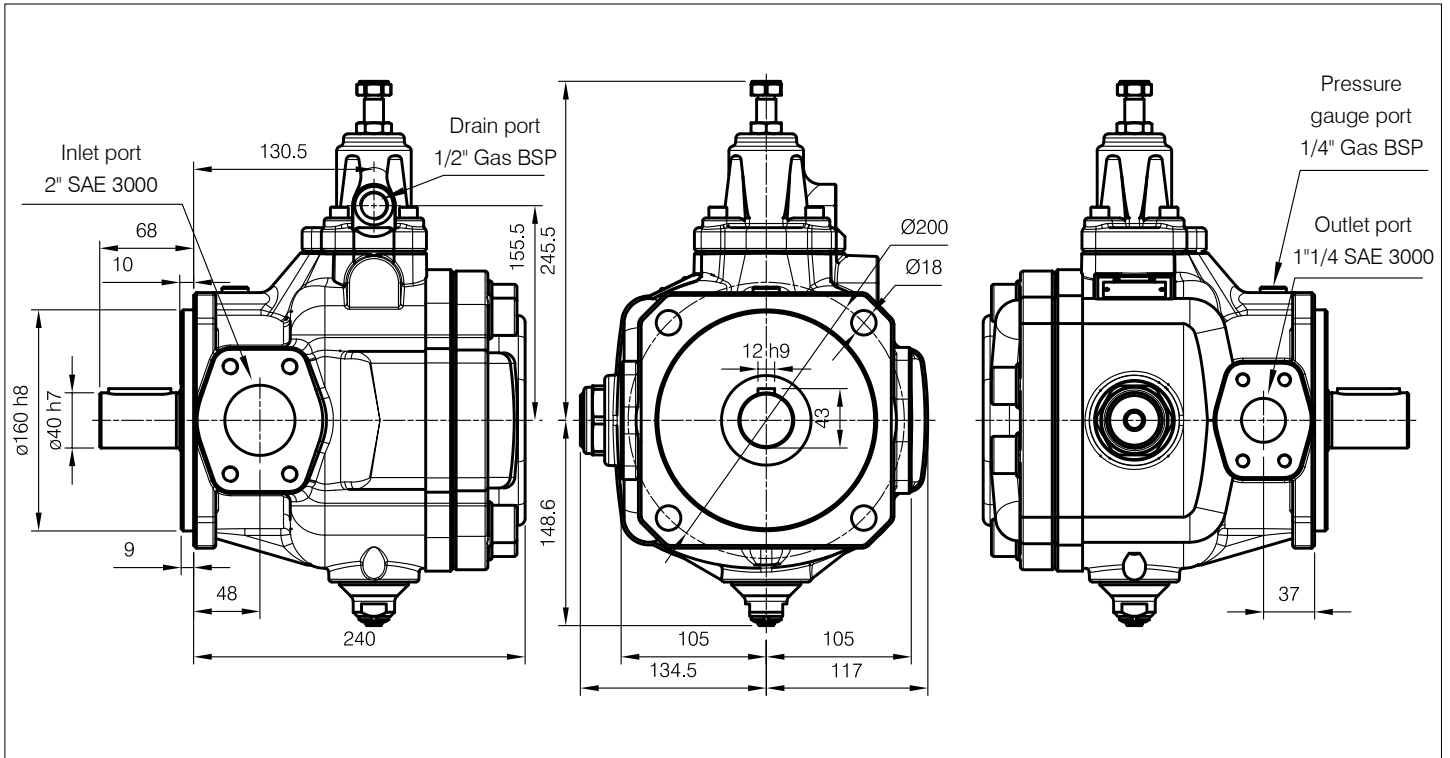

01 PLP 3-(80-100-120) + Option "A"

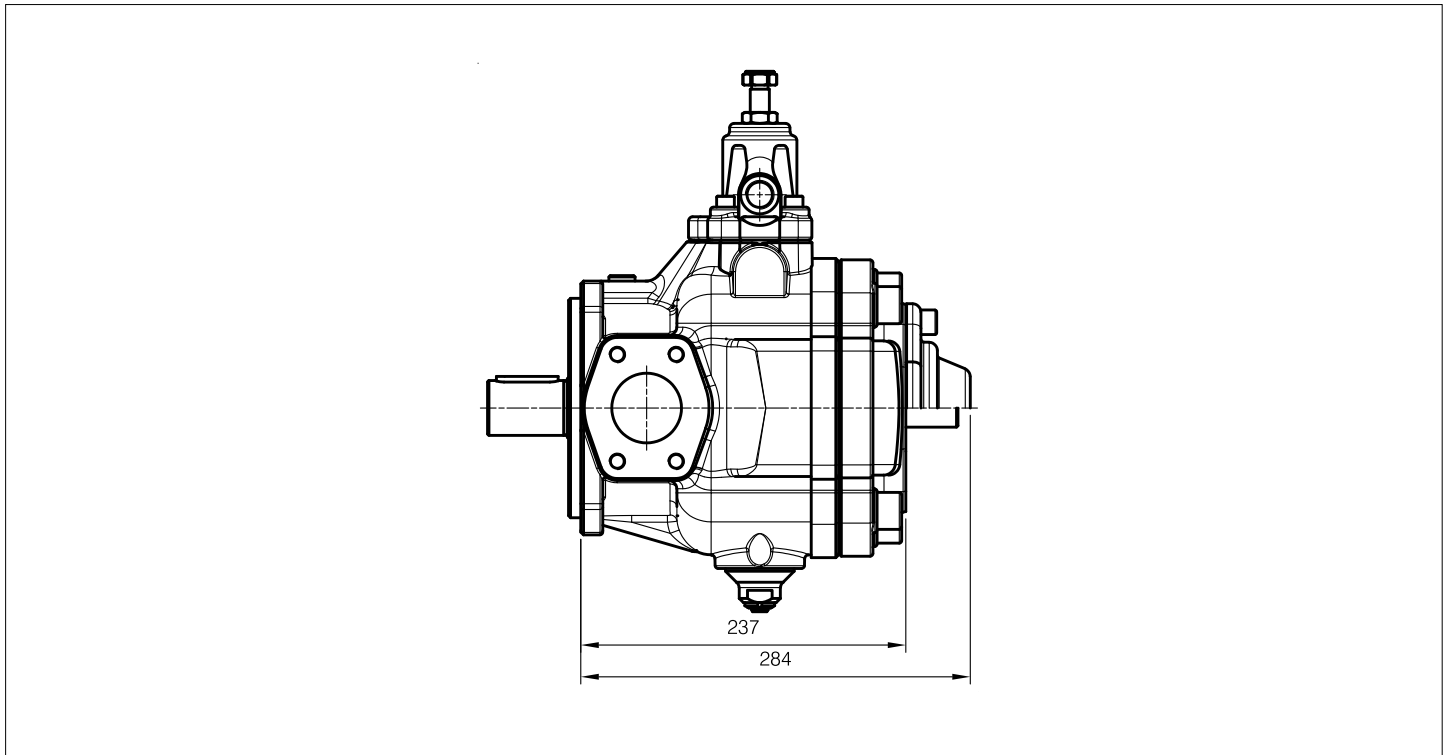

For information, please refer to related **Catalog COUPLINGS and ACCESSORIES**

Settings

Pressure

All Berarma PLP pumps are equipped with a mechanical pressure adjustment device that allow to adjust the maximum working pressure of the pump. By screwing clockwise, the pressure increases.

Warning

Do not go out of the pressure setting range.

During the first start-up, make sure that the pressure adjustment screw is screwed enough to ensure the correct pump priming.

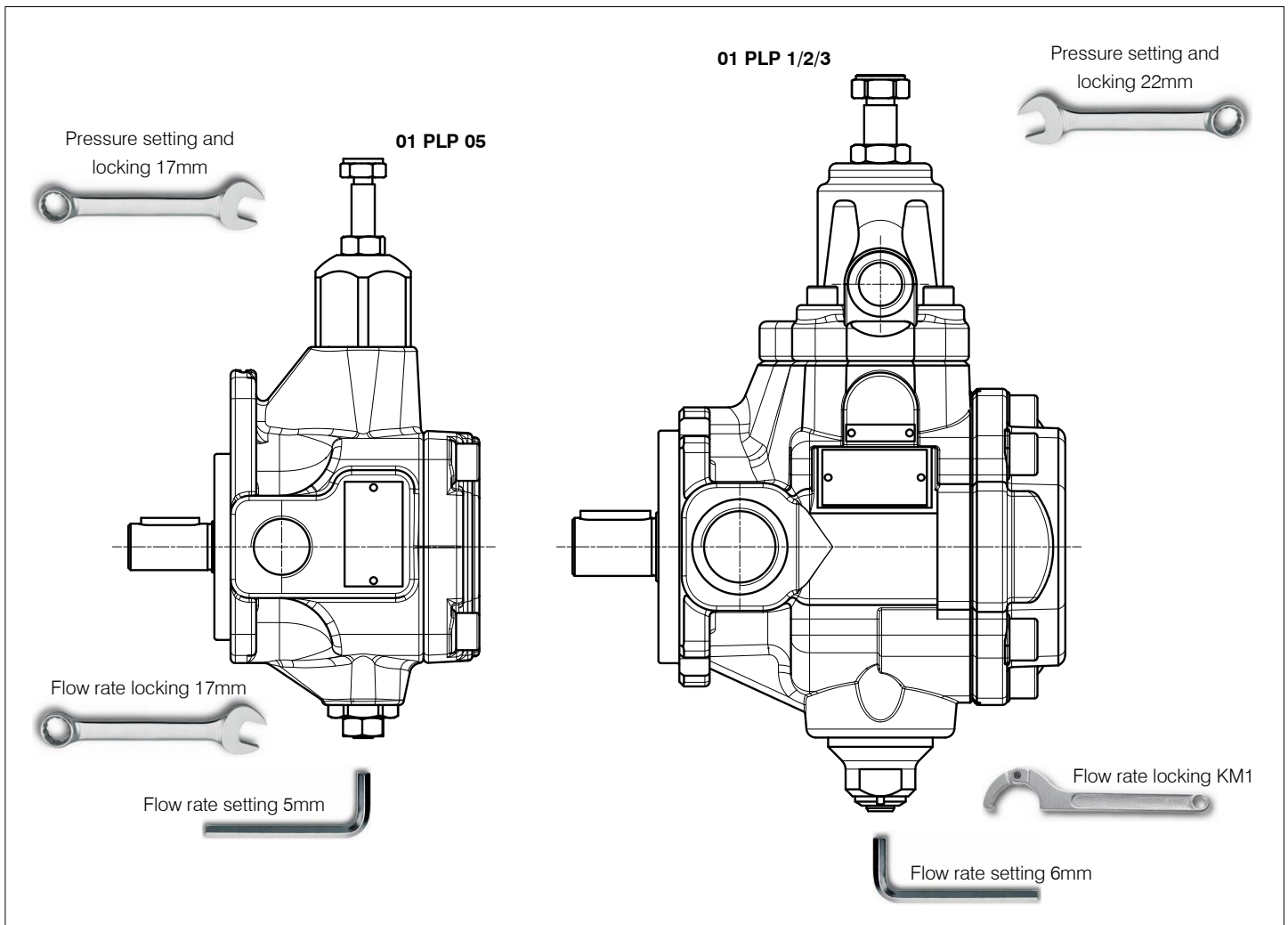

Flow rate

All Berarma pumps are equipped with a flow regulator device that allow the mechanical reduction of the maximum pump displacement compared to the nominal value. By screwing clockwise, the flow rate decreases.

Warning

If the flow regulator device is set to less than 50% of the nominal displacement, the pump can only start on condition that the system and pump are completely filled with fluid.

Pump type	Actual displacement (cm ³ /r)	Reduced displacement by screw turn (cm ³ /r)	Minimum displacement (cm ³ /r)
01 PLP 05 - 16	17	10	2.5
01 PLP 1 - 20	21	13	11.5
01 PLP 1 - 25	26	13	16.5
01 PLP 1 - 32	33	13	22
01 PLP 2 - 40	41	17	26.5
01 PLP 2 - 50	50	17	33.5
01 PLP 2 - 63	63	17	42
01 PLP 3 - 80	81	27	51
01 PLP 3 - 100	100	27	73
01 PLP 3 - 120	120	27	95

Indicative values influenced by manufacturing tolerances

Accessories

Electric motors with special flange and hollow shaft for direct coupling with Berarma pumps size 05 and 1.
 For information, please refer to related **GMP Catalog**

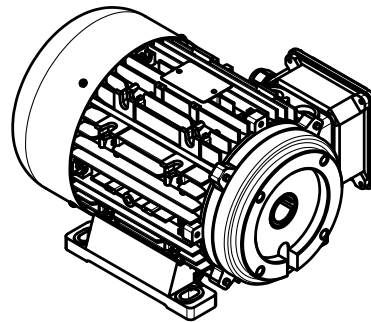

Non return valves integrated on SAE flange, ideal to be installed on Berarma Berarma pump size 2 and 3 outlet port or for installation on hydraulic systems.
 For information, please refer to related **NRV Catalog**

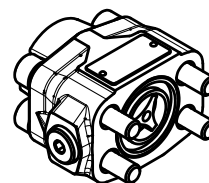

Coupling unit that allow to arrange combined pumps between Berarma pumps or the main other types of pump available on the fluid power market.
 For information, please refer to related **COUPLINGS and ACCESSORIES Catalog**

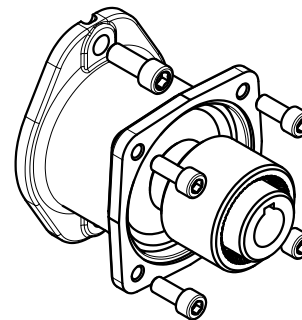

SAE 3000 flanges ideal to be installed on Berarma pump size 2 and 3 inlet and outlet ports.
 For information, please refer to related **COUPLINGS and ACCESSORIES Catalog**

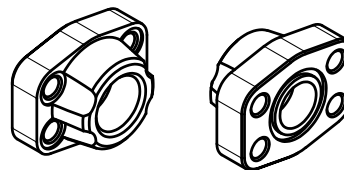

Warning

All Berarma pumps have been carefully checked during manufacture and subjected to testing cycles before shipment.
 To achieve optimum performance, avoid problems and maintain the warranty, **Document USE AND MAINTENANCE MANUAL**, available on our website, must be strictly observed.

Notes

Before selection and/or use of any Berarma product, it is important that the purchaser carefully analyses all aspects of its application and reviews the information in the current Berarma technical sales documents. Due to the many different operating conditions and applications for Berarma products, the purchaser, through their own analysis and testing, is solely responsible for making the final selection of the products and assuring that all performance and safety requirements are met. Berarma S.r.l. accepts no responsibility for any editing mistakes in this catalogue. Berarma S.r.l. reserves the right to modify the products and data contained in this catalogue at any time and without prior notice.