

BERARMA
oleodinamica

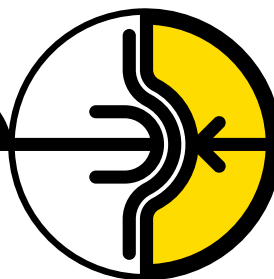

Variable displacement vane pump with horse power limiter compensator device

PHPK

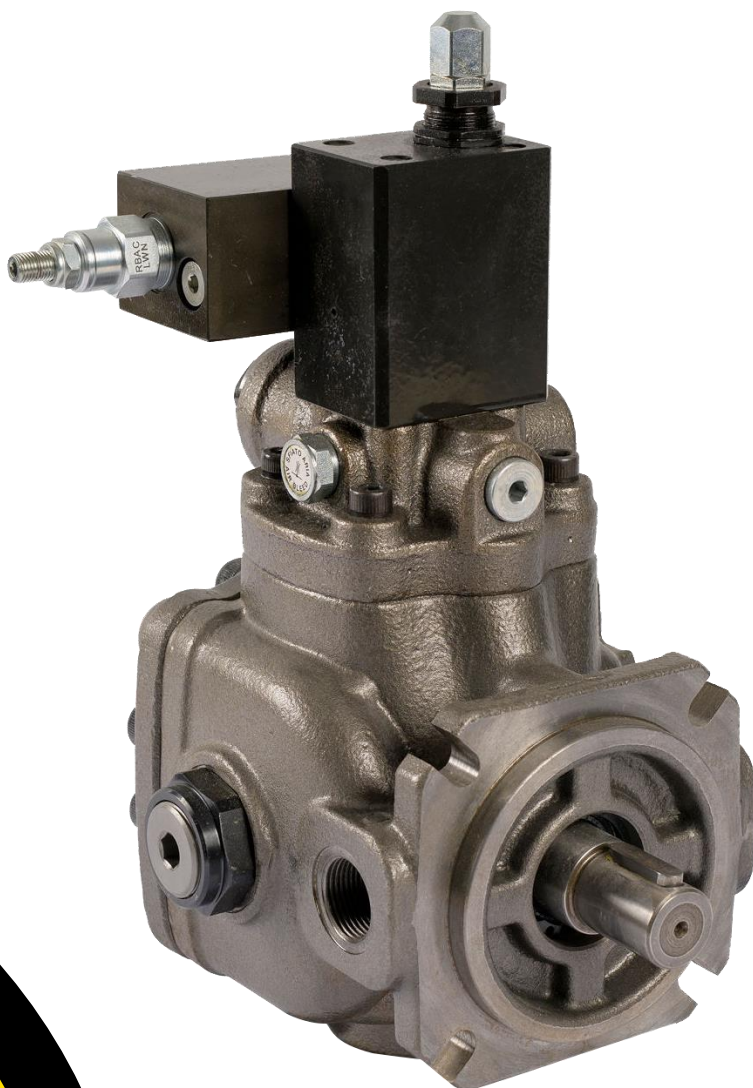

Series Name	Displacement [cm ³ /r]	Flow rate at 1450rpm [l/min]	Max. pressure [bar]
01 PHPK 1-20	20	29	180
01 PHPK 1-25	25	36	180
01 PHPK 1-32	32	47	180
01 PHPK 2-40	40	58	180
01 PHPK 2-50	50	73	180
01 PHPK 2-63	63	92	180
01 PHPK 3-80	80	116	180
01 PHPK 3-100	100	145	180
01 PHPK 3-120	120	174	180

General description

PHPK pumps are high pressure variable displacement vane pumps equipped with hydraulic horse power limiter device that allow you to instantly adjust the flow rate accordingly to circuit requirements. Variable displacement vane pumps are volumetric type so they deliver a maximum flow rate equivalent to its displacement for their speed of rotation. Operating pressure is due to pressure loads encountered by the fluid within the system. When the outlet pressure (on the system) equals the pump setting pressure, the flow rate is adjusted to the values required by the system. When this value is achieved, pump reduces its flow rate to zero, keeping the pressure almost constant. In zero flow conditions, pump delivers oil only to compensate any possible drain and piloting.

In addition, the horse power limiter device allows to optimize power consumption. The operating principle is based on maintaining the flow-pressure product ($q \times p$) practically constant, so that when the pressure increases, the flow decreases and vice versa, according to a characteristic hyperbolic-type curve.

Berarma PHPK pumps are especially suited for those systems with a work cycle consisting of two operating phases:

- a first phase characterized by a quick approach at low pressure
- a second phase characterized by low speed and high pressure (e.g. forming, drawing, blanking presses, etc.)

In this way, it is possible to set up a system using only one pump, where previously two pumps were required, resulting in obvious cost savings.

The PHPK series pumps combines the characteristics of other Berarma variable displacement vane pumps with

- Silent running
- High efficiency
- Long working life
- Economy and simplification of hydraulic system
- Modular design
- Energy saving

What makes the Berarma PHPK series pumps very interesting for the market?

- Dual inlet and outlet channels in the internal pump cartridge
- Dual axial hydrostatic balancing on the distribution plates
- Wear reduction of the internal pump cartridge parts
- Innovative shapes and design
- 180bar working pressure

How to order

The PHPK pump can be ordered in two different ways:

- 1) starting from the power value of the motor (contact Berarma technical service to find out the available power values) and from the maximum working pressure, thus obtaining a characteristic curve making it possible for the pump to optimize installed power usage.
- 2) starting from the minimum flow value to be obtained at the previously defined maximum working pressure. In this way the motor power and the characteristic curve are determined from defined operating conditions.

Starting from the motor power value and maximum working pressure value indicated in the ordering code, Berarma performs the bench calibration of the constant power device so that the actual characteristic curve of the pump approximates the theoretical hyperbolic curve (see image below).

It is possible to change the power calibration by the user by strictly following the instructions in the related procedure available on the website and / or by contacting the Berarma technical service.

Pump absorbed power can be calculated using the following formula:

$$\text{Power [kW]} = \frac{\text{pressure [bar]} \times \text{flow [l/min]}}{600 \times \text{total efficiency}}$$

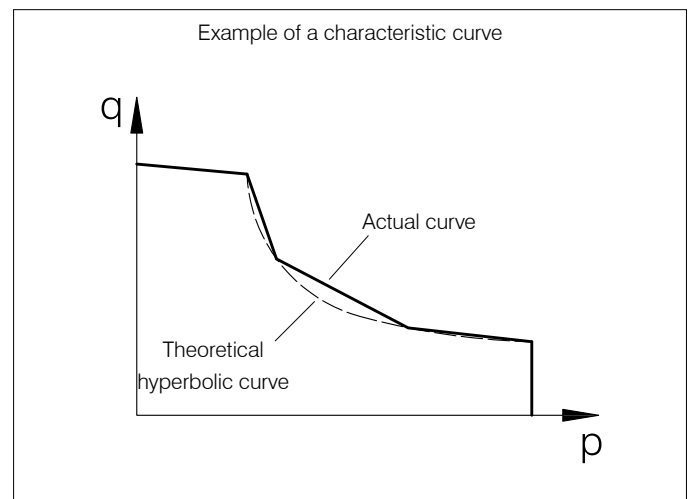

Technical data

Size	1	2	3
Geometric displacement according to ISO 3662 (cm ³ /r)	20 ÷ 25 ÷ 32	40 ÷ 50 ÷ 63	80 ÷ 100 ÷ 120
Actual displacement (cm ³ /r) Due to manufacturing tolerances, the value can vary by approx. ±3%	21 ÷ 26 ÷ 33	41 ÷ 50 ÷ 63	81 ÷ 100 ÷ 120
Maximum working pressure (bar) Pressure peak exceeding 30% of the maximum operating pressure must be eliminated by adopting the appropriate measures	180 The maximum achievable pressure depends on the required power setting		
Permitted maximum drain port pressure (bar)	1		
Inlet pressure (bar)	0.8 ÷ 1.5 absolute		
Speed range (rpm)	800 ÷ 1800	800 ÷ 1500 1800 allowed with max. pressure 160bar	
Rotation direction	R: right (clockwise) viewed from shaft end		
Load on drive shaft	NO RADIAL OR AXIAL LOADS ALLOWED		
Hydraulic fluid for other fluids please contact Berarma technical sales service	HM according to ISO 6743-4 HLP according to DIN 51524-2		
	HEES according to ISO 15380 FPM-Viton seals ÷ Pmax 160bar		
	HFD according to ISO 12922 FPM-Viton seals ÷ Pmax 160bar		
	HFC according to ISO 12922 water <40% ÷ NBR seals ÷ Pmax 100bar ÷ Vmax 1000rpm ÷ Temp. <40°C		
Viscosity range (cSt, mm ² /s)	22 ÷ 68 at operating temperature		
Starting viscosity under full flow conditions (cSt, mm ² /s)	400 max.		
Viscosity index according to ISO 2909	100 min.		
Inlet fluid temperature range (°C)	+ 15 / + 60 ÷ pay attention to viscosity range		
Maximum acceptable fluid contamination level	20/18/15 according to ISO 4406 CLASS 9 according to NAS 1638		
Recommended fluid contamination level for a longer pump working life	18/16/13 according to ISO 4406 CLASS 7 according to NAS 1638		
Moment of inertia (kgm ²)	0.0005	0.00909	0.015
Weight single pump (kg)			
Standard control	21.9	39.2	57.2
PCS002 control	22	39.3	57.3
PCS003 control	21.7	39	57
For further information and/or different operating conditions please contact Berarma technical sales service			

Installation and start-up

For the installation and start-up of Berarma pumps please refer to related **Document USE AND MAINTENANCE MANUAL** available on our website.



Ordering code

Series Name	Size Displacement	Flange	Pressure setting	Rotation	Seals	Options	Pressure control	Power setting	Max. Pressure
01 PHPK	2 - 50	F	H	R	M	A	PCS003	7.5	180

Code	Size	Displacement cm³/r
1 - 20	1	20
1 - 25	1	25
1 - 32	1	32
2 - 40	2	40
2 - 50	2	50
2 - 63	2	63
3 - 80	3	80
3 - 100	3	100
3 - 120	3	120

Code	Flange	Ports
F	ISO 3019-2 4 holes	Gas BSP SAE 3000

Code	Pressure setting (bar)
H	180 depends on power setting

Code	Rotation direction
R	Right (CW) viewed from shaft

Code	Seals
M	NBR
E	FPM - Viton

Code	Option
/	Omit for no option
A	Thru drive shaft for combined pumps

Code	Pressure control
/	Single stage of pressure
PCS002	Single stage of pressure with remote pressure control
PCS003	Two stages of pressure, one with fixed setting at the minimum pressure

Code	Power setting
kW	Indicate the pump setting power value

Code	Maximum pressure
bar	Indicate the pump setting maximum working pressure value

Overall dimensions

01 PHPK 1-(20-25-32) – Single stage of pressure

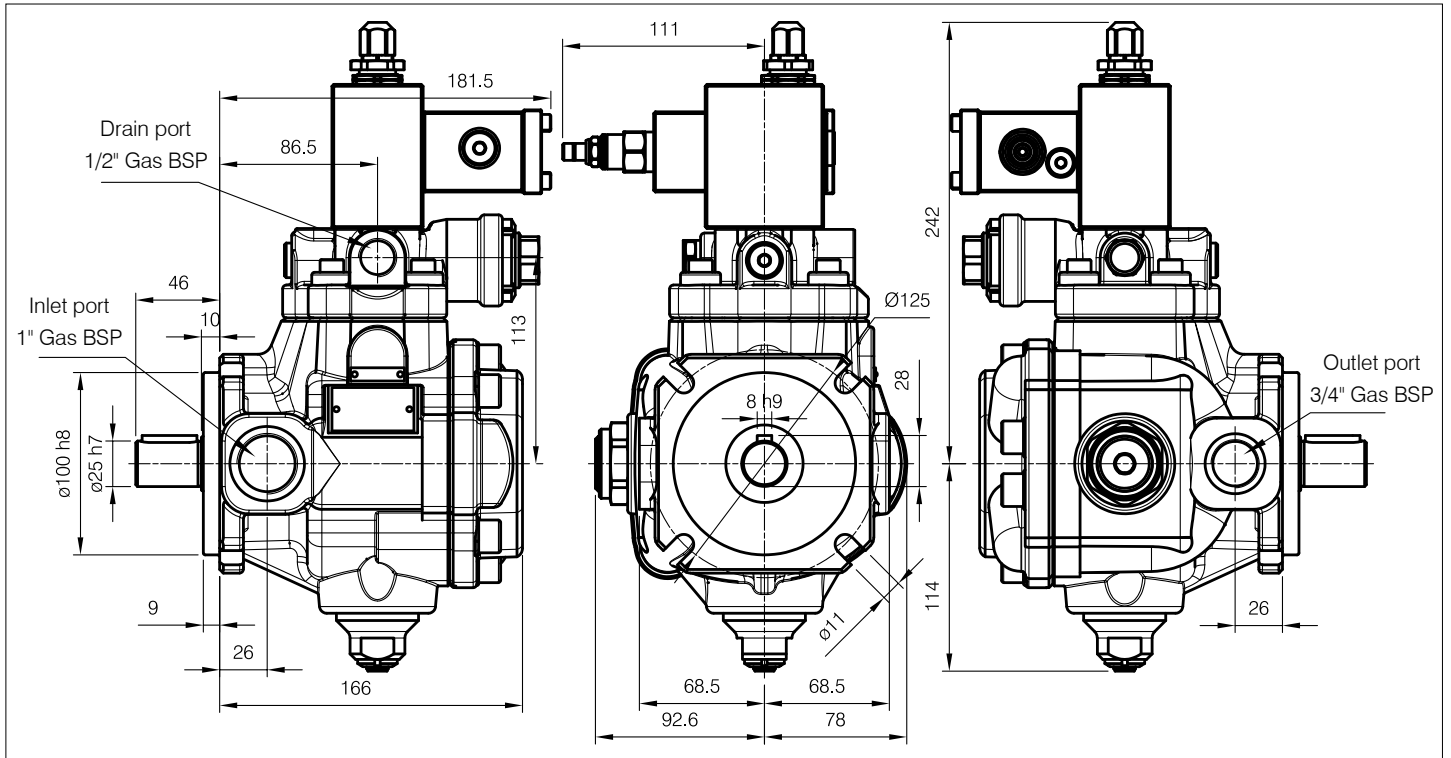

01 PHPK 1-(20-25-32) + Option "A"
Single stage of pressure

01 PHPK 1-(20-25-32)
PCS002 pressure control

01 PHPK 1-(20-25-32)
PCS003 pressure control

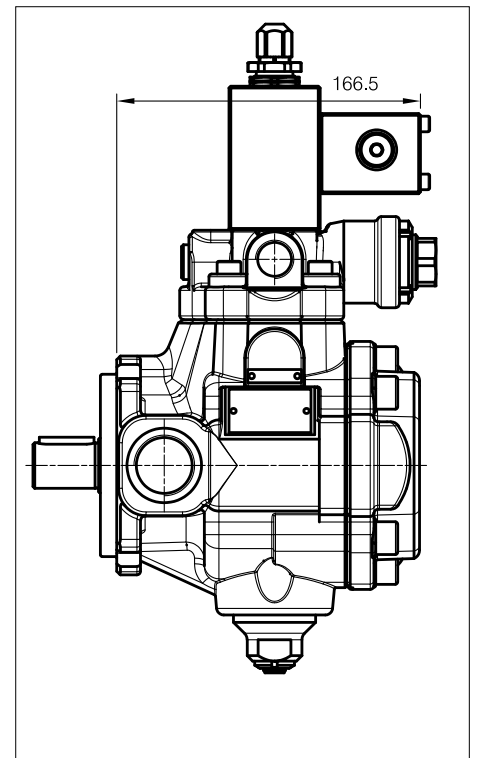
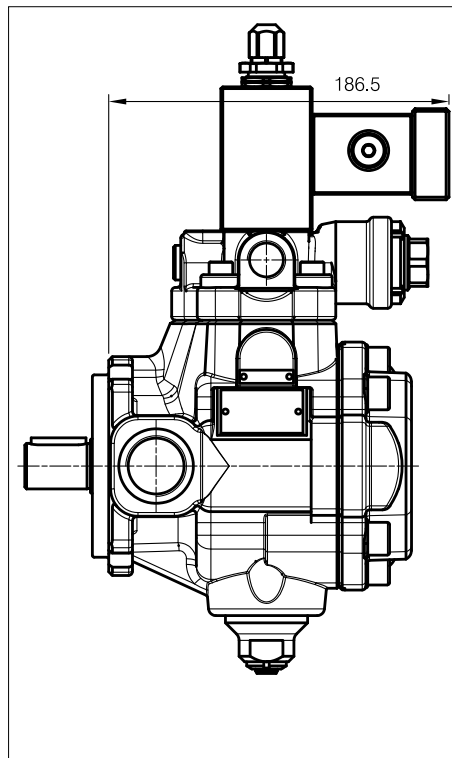
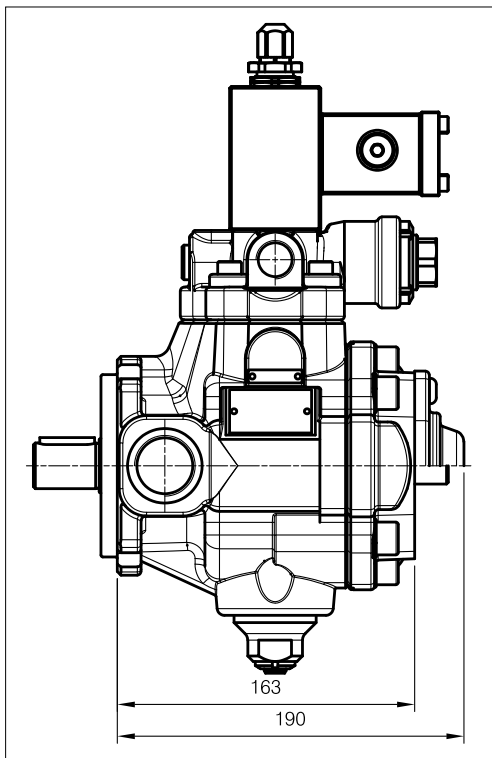

For information, please refer to related **Catalog COUPLINGS and ACCESSORIES**

Overall dimensions

01 PHPK 2-(40-50-63) – Single stage of pressure

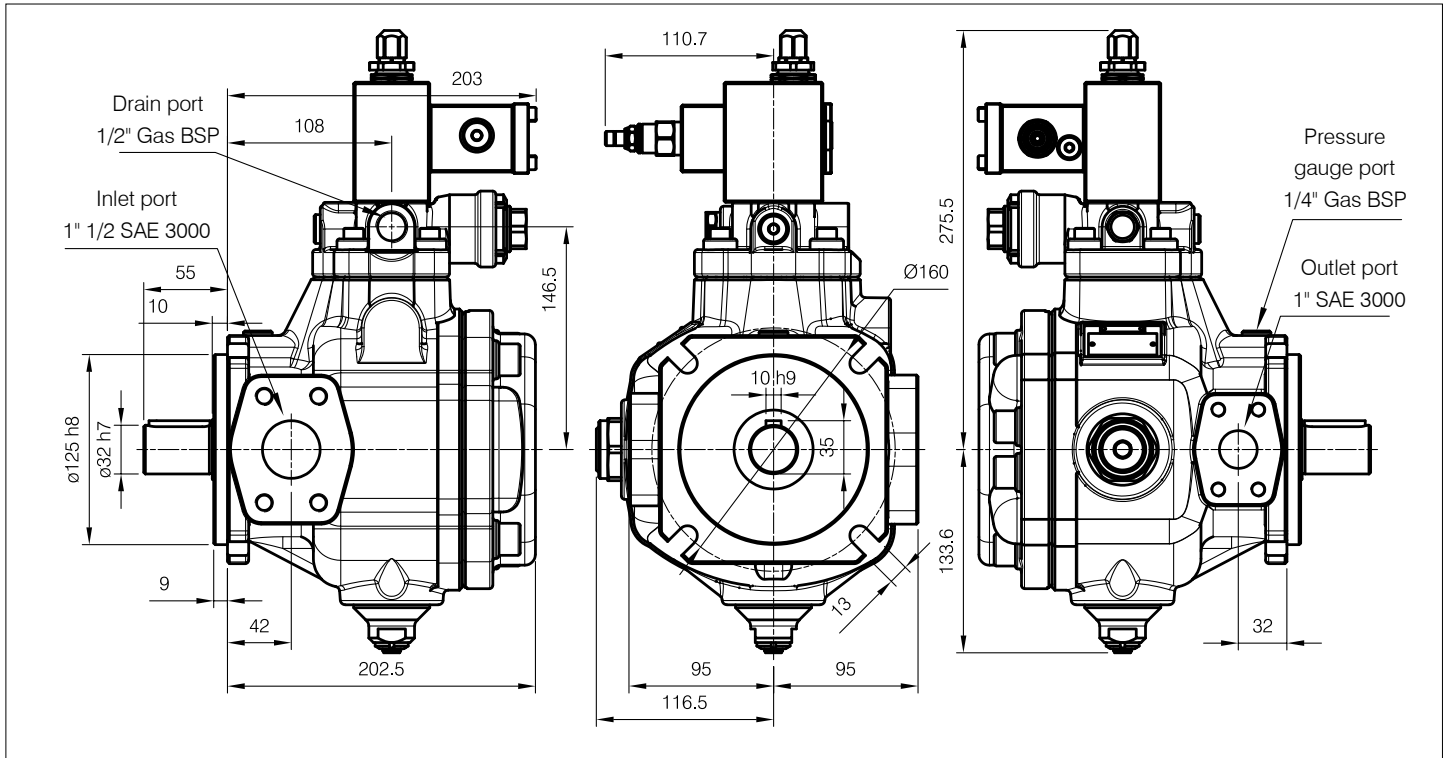

01 PHPK 2-(40-50-63) + Option "A"
Single stage of pressure

01 PHPK 2-(40-50-63)
PCS002 pressure control

01 PHPK 2-(40-50-63)
PCS003 pressure control

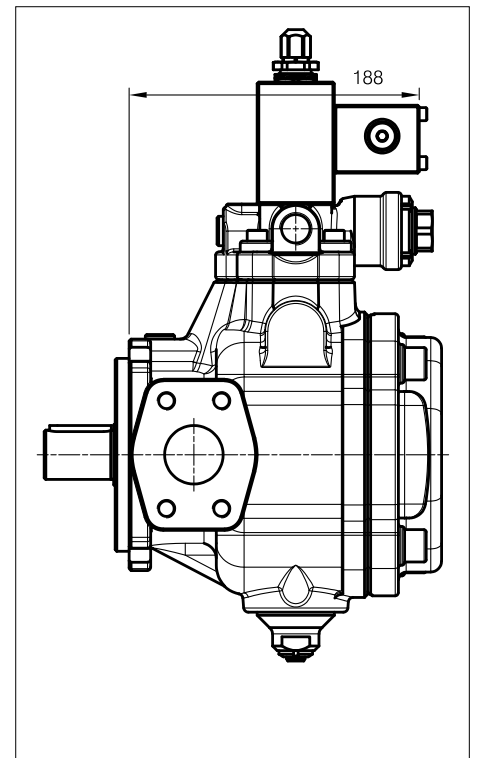
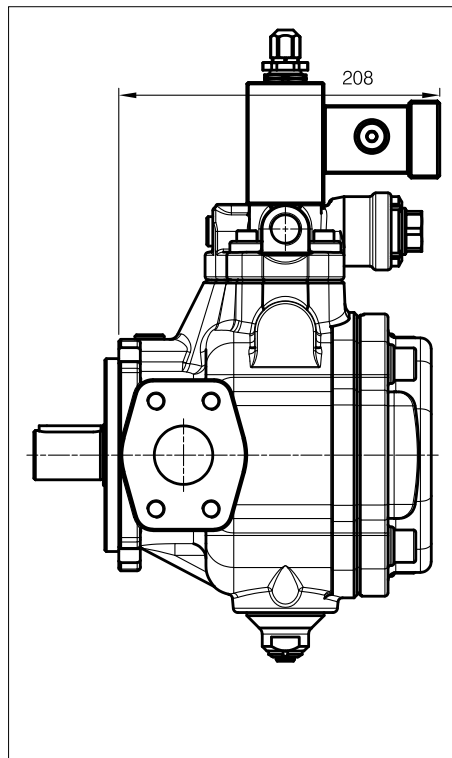
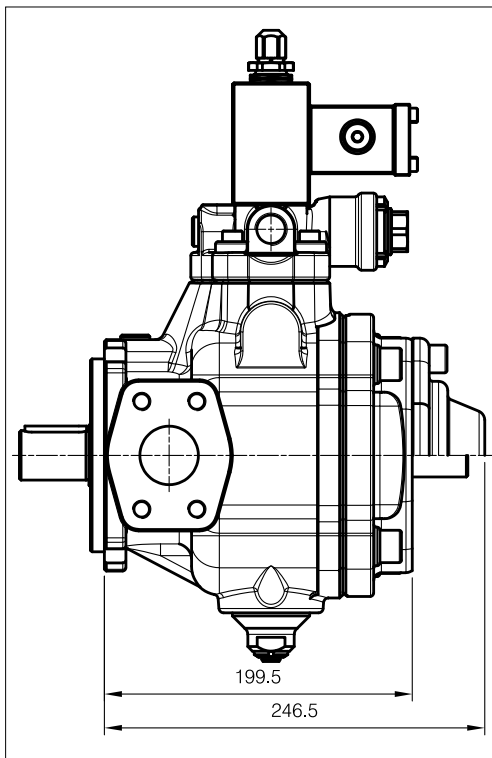

For information, please refer to related **Catalog COUPLINGS and ACCESSORIES**

Overall dimensions

01 PHPK 3-(80-100-120) – Single stage of pressure

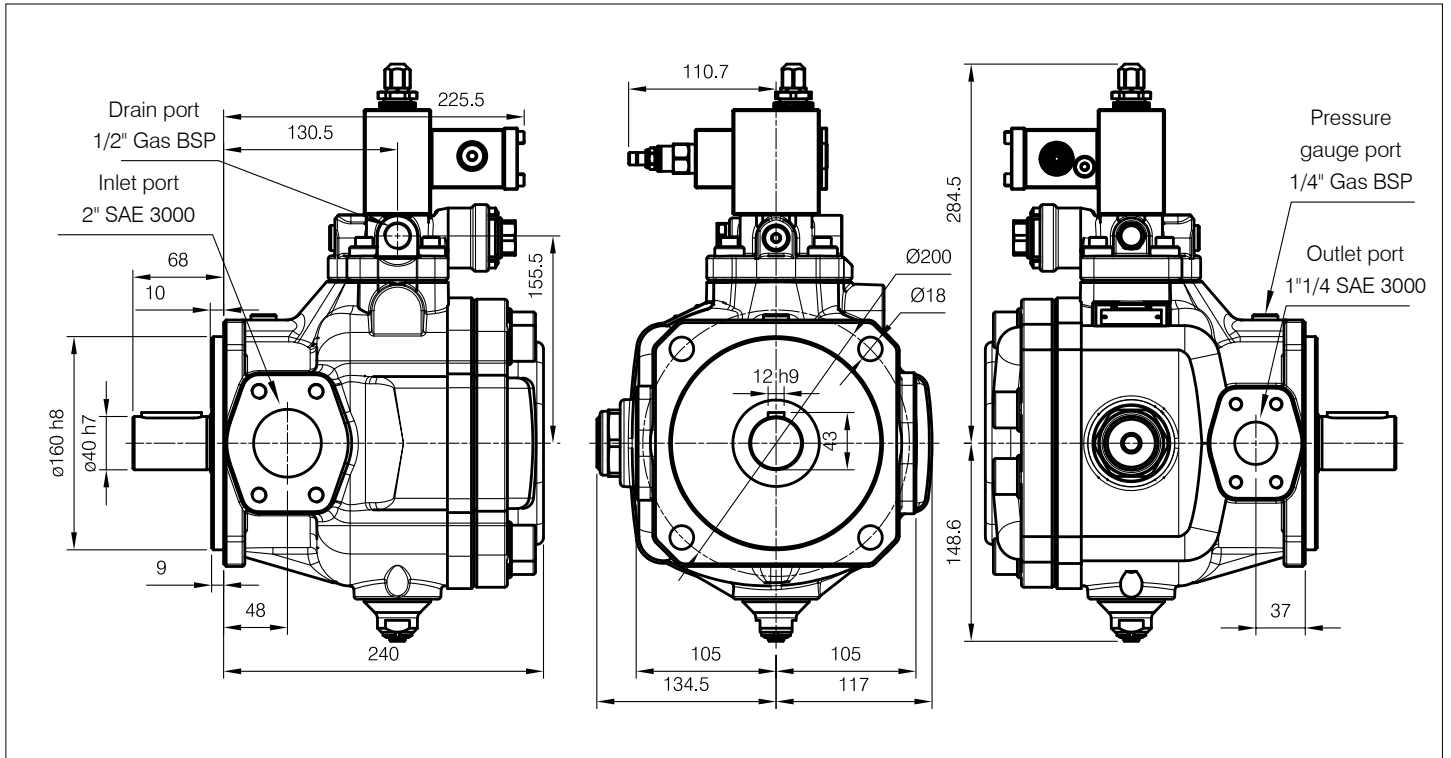

01 PHPK 3-(80-100-120) + Option "A"
Single stage of pressure

01 PHPK 3-(80-100-120)
PCS002 pressure control

01 PHPK 3-(80-100-120)
PCS003 pressure control

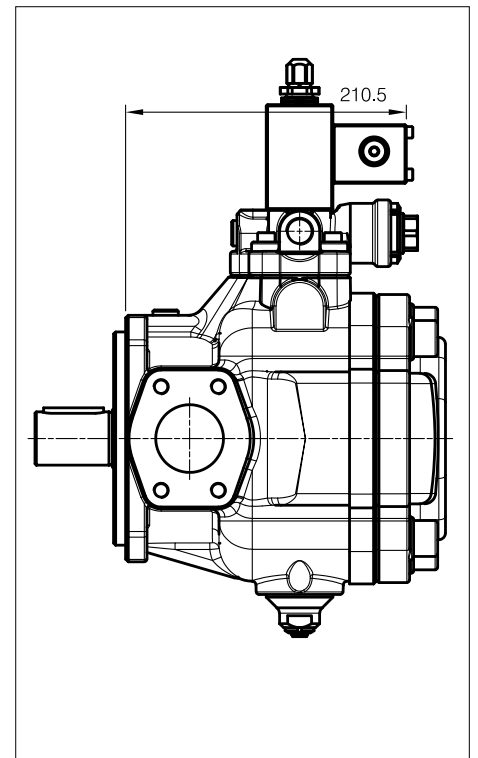
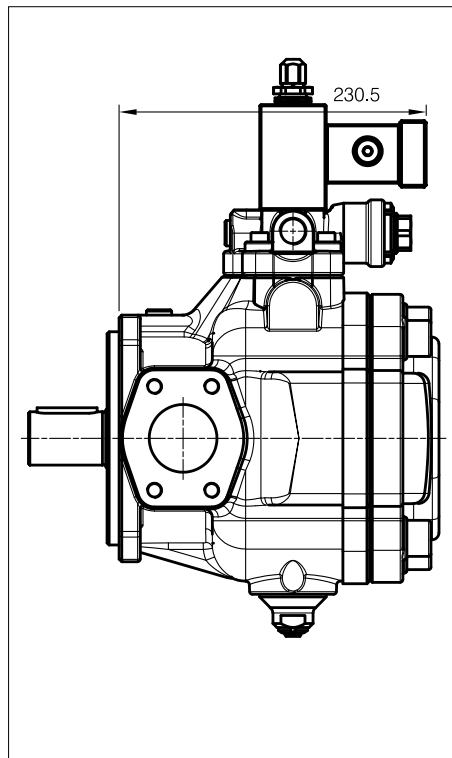
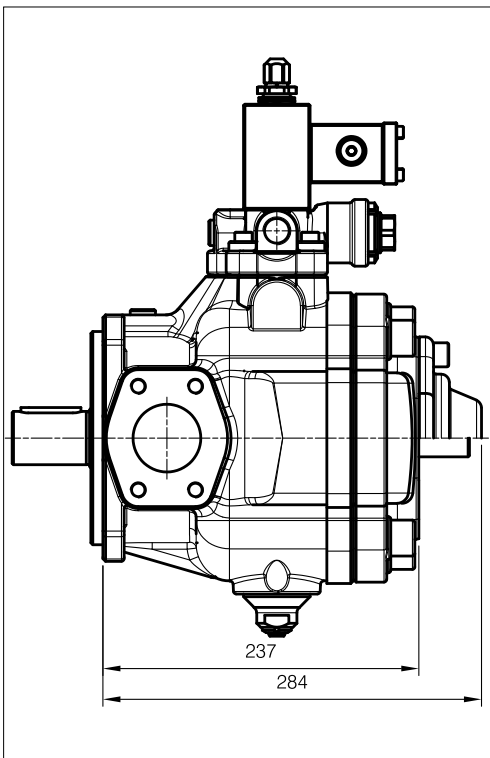

For information, please refer to related **Catalog COUPLINGS and ACCESSORIES**

Pressure controls

Single stage of pressure

This standard control enables the pump displacement to be adjusted (until zero flow setting condition) according to the flow rate required by the hydraulic system, keeping the horse power under the limit set on the compensator device according to the value defined in the order.
The pressure value setting of the compensator device is adjusted by means of the pressure setting screw and locked using the locknut.

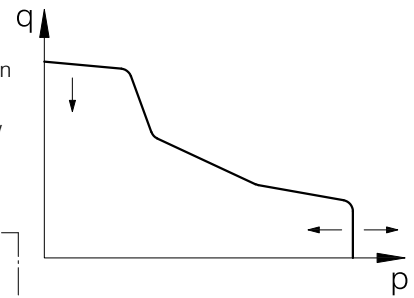
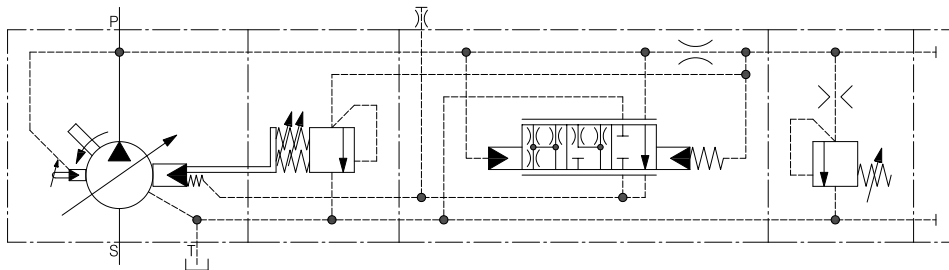

PCS002 - Single stage of pressure with remote pressure control

The function of this control is the same as the standard control function with the possibility of adjusting the working pressure by means of an additional maximum pressure relief valve (**not supplied**) installed in a remote position, far from the pump.
Control performances depends on the additional valve type and on its distance from the pump.
To obtain the best performance, it is recommended to use maximum pressure relief valves with flow rates from 2 to 5 l / min and not to exceed 5 meters of pipe length.

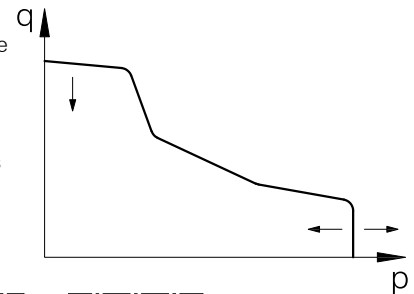
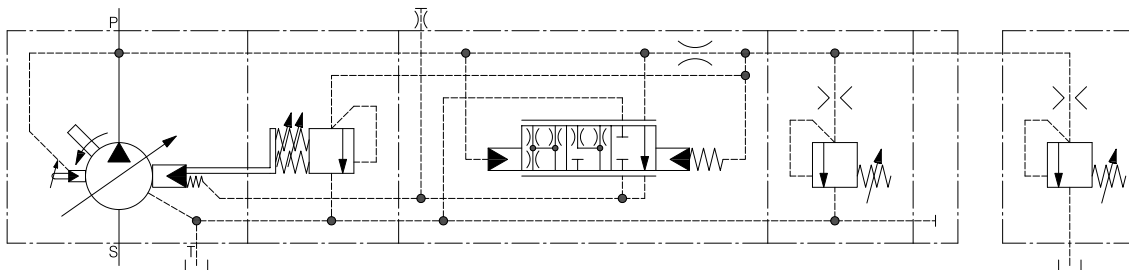

PCS003 - Two stages of pressure, one with fixed setting at the minimum pressure

The function of this control is the same as the standard control with the possibility to mount a directional control valve ISO 4401-03 (CETOP 03 - NG6) (**not supplied**) on the top of the compensator in order to switch between two working pressure levels, one of which is fixed at the minimum pressure that depend from the horse power limiter setting.
Control performance depends on the type of additional directional control valve.

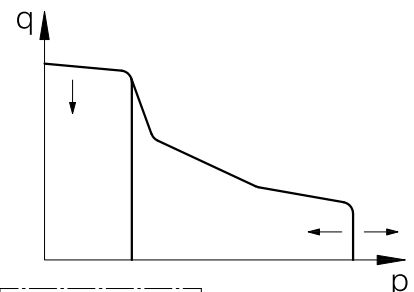
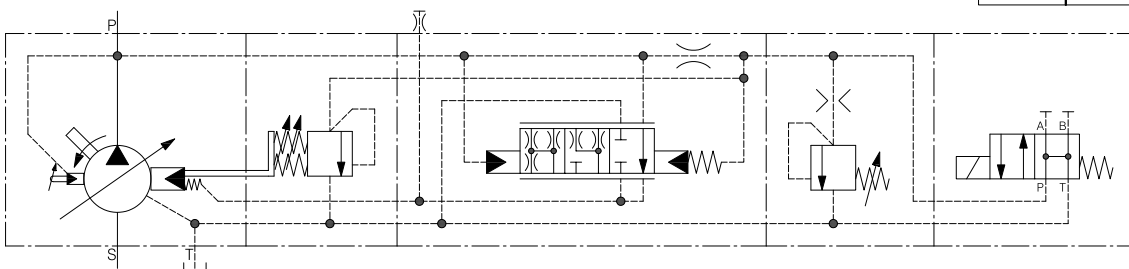

Settings

Pressure

All Berarma PHPK pumps are equipped with a hydraulic pressure adjustment device with horse power limiter that allow to adjust the maximum working pressure of the pump. By screwing clockwise, the pressure increases.

Warning

Do not go out of the pressure setting range.

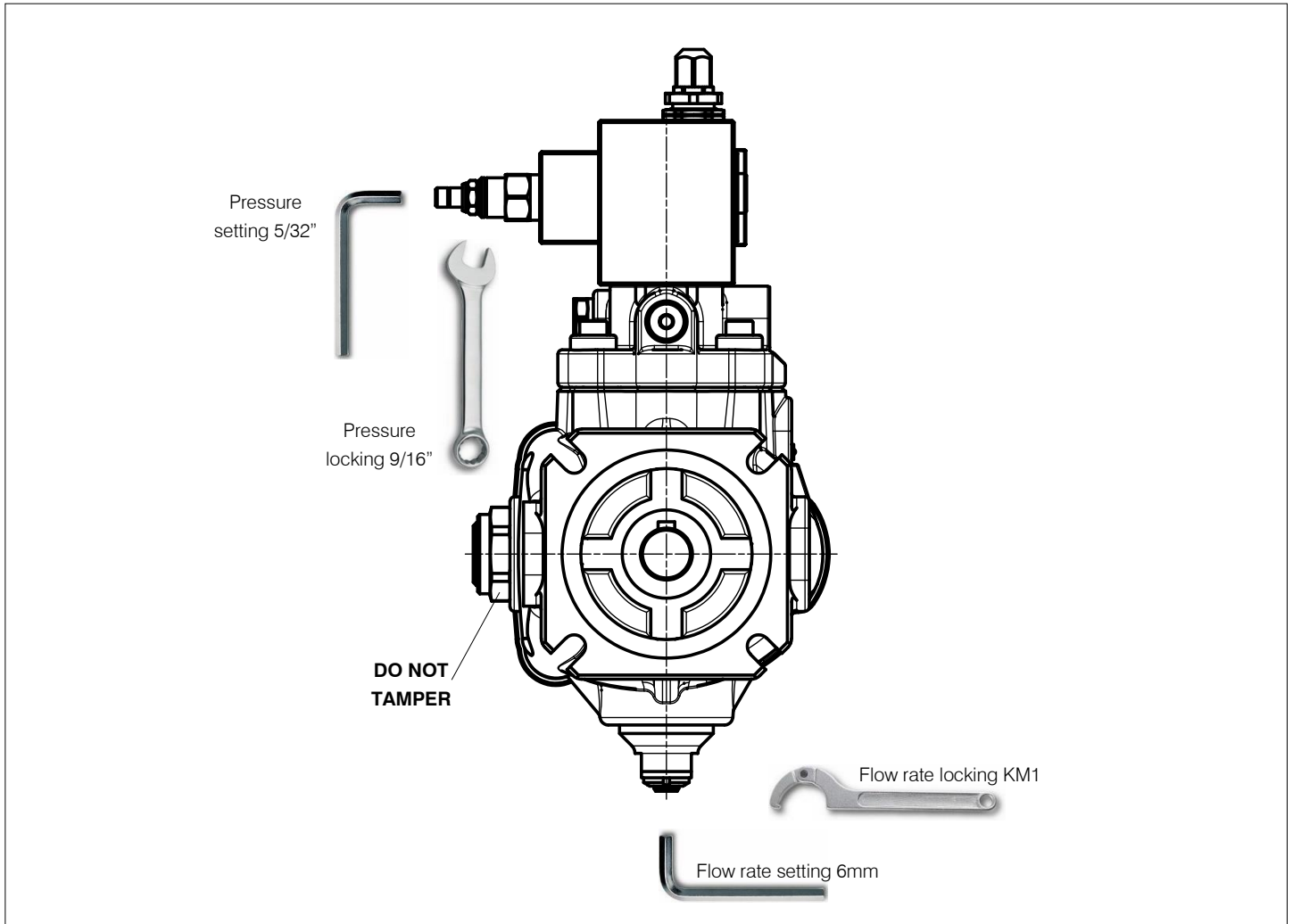

Flow rate

All Berarma pumps are equipped with a flow regulator device that allow the mechanical reduction of the maximum pump displacement compared to the nominal value. By screwing clockwise, the flow rate decreases.

Warning

If the flow regulator device is set to less than 50% of the nominal displacement, the pump can only start on condition that the system and pump are completely filled with fluid.

Pump type	Actual displacement (cm ³ /r)	Reduced displacement by screw turn (cm ³ /r)	Minimum displacement (cm ³ /r)
01 PHPK 1 - 20	21	13	11.5
01 PHPK 1 - 25	26	13	16.5
01 PHPK 1 - 32	33	13	22
01 PHPK 2 - 40	41	17	26.5
01 PHPK 2 - 50	50	17	33.5
01 PHPK 2 - 63	63	17	42
01 PHPK 3 - 80	81	27	51
01 PHPK 3 - 100	100	27	73
01 PHPK 3 - 120	120	27	95

Indicative values influenced by manufacturing tolerances

Accessories

Electric motors with special flange and hollow shaft for direct coupling with Berarma pumps size 05 and 1.
For information, please refer to related **GMP Catalog**

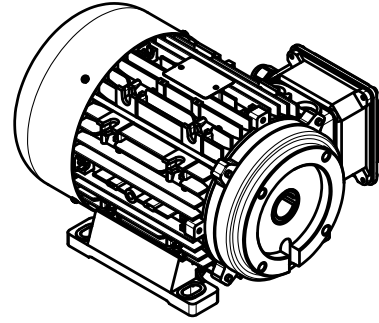

Non return valves integrated on SAE flange, ideal to be installed on Berarma Berarma pump size 2 and 3 outlet port or for installation on hydraulic systems.
For information, please refer to related **NRV Catalog**

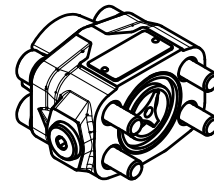

Coupling unit that allow to arrange combined pumps between Berarma pumps or the main other types of pump available on the fluid power market.
For information, please refer to related **COUPLINGS and ACCESSORIES Catalog**

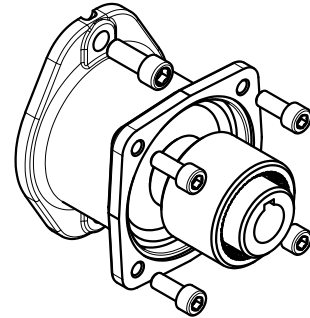

SAE 3000 flanges ideal to be installed on Berarma pump size 2 and 3 inlet and outlet ports.
For information, please refer to related **COUPLINGS and ACCESSORIES Catalog**

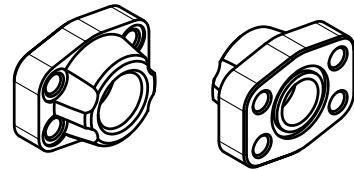

Warning

All Berarma pumps have been carefully checked during manufacture and subjected to testing cycles before shipment.
To achieve optimum performance, avoid problems and maintain the warranty, **Document USE AND MAINTENANCE MANUAL**, available on our website, must be strictly observed.

Notes

Before selection and/or use of any Berarma product, it is important that the purchaser carefully analyses all aspects of its application and reviews the information in the current Berarma technical sales documents. Due to the many different operating conditions and applications for Berarma products, the purchaser, through their own analysis and testing, is solely responsible for making the final selection of the products and assuring that all performance and safety requirements are met. Berarma S.r.l. accepts no responsibility for any editing mistakes in this catalogue. Berarma S.r.l. reserves the right to modify the products and data contained in this catalogue at any time and without prior notice.